

Illustration 1

Question: If the flux of magnetic induction through a coil changes from $\phi_1 = 10$ Wb to $\phi_2 = 20$ Wb then find the charge q that flows through the circuit of total resistance $R = 10\Omega$.

Solution: Let ϕ be the instantaneous flux. Then $\frac{d\phi}{dt}$ is the instantaneous rate of change of flux which is equal to the magnitude of the instantaneous emf. So current in the circuit $|i| = \frac{1}{R} \left(\frac{d\phi}{dt} \right)$, since current is the rate of flow of charge, that is, $i = \frac{dq}{dt}$

$$q = \int idt \quad \text{or} \quad q = \int_{t=0}^{t=\tau} \left(\frac{d\phi}{dt} / R \right) dt$$

where τ is the time during which change takes place. But at $t = 0$, $\phi = \phi_1$ and at $t = \tau$, $\phi = \phi_2$

$$\therefore q = \frac{1}{R} \int_{\phi=\phi_1}^{\phi=\phi_2} d\phi = \frac{\phi_2 - \phi_1}{R} = \frac{20 - 10}{10} = 1 \text{ C}$$

Illustration 2

Question: A 10 ohm coil of mean area 500 cm^2 and having 1000 turns is held perpendicular to a uniform field of $0.4 \times 10^{-4} \text{ T}$. The coil is turned through 180° in $(1/10) \text{ s}$. Calculate (a) the change in flux (in mWb) (b) the average induced emf (in mV) (c) average induced current (in mA) and (d) the charge (in μC) that flows in the circuit.

Solution: (a) When the plane of coil is perpendicular to the field as shown in figure (a) the angle between area

\vec{S} and field \vec{B} is 0° . So the flux linked with the coil,

$$\phi_1 = NSB \cos 0^\circ = NSB$$

When the coil is turned through 180° as shown in figure (b), the flux linked with the coil will be $\phi_2 = NSB \cos 180^\circ = -NSB$

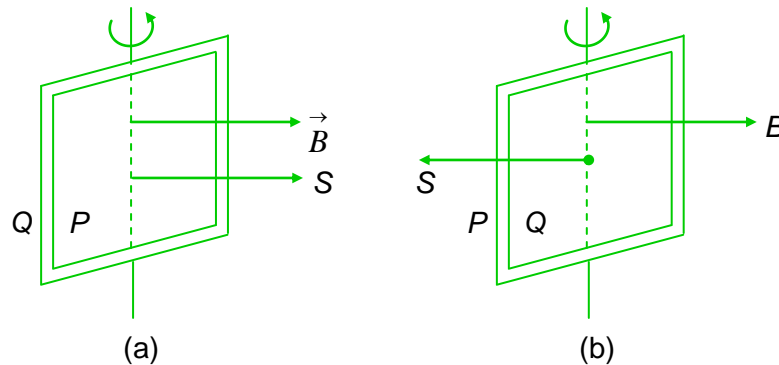

So change in flux,

$$\Delta\phi = \phi_2 - \phi_1 = -NSB - (NSB) = -2NSB$$

i.e., $|\Delta\phi| = 2 \times 10^3 \times (500 \times 10^{-4}) \times (0.4 \times 10^{-4}) = 4$

(b) As in turning through 180° , i.e., in change of flux $\Delta\phi$, the coil takes $(1/10) \text{ s}$,

$$|\epsilon_{av}| = \frac{|\Delta\phi|}{\Delta t} = \frac{2NSB}{\Delta t} = \frac{4 \times 10^{-3}}{10^{-1}} = 40$$

(c) $I_{av} = \frac{\epsilon_{av}}{R} = \frac{0.04}{10} = 4$

(d) the charge that flows through the circuit $= \frac{\Delta\phi}{R} = \frac{4 \times 10^{-3}}{10} \text{ C} = 400$

Illustration 3

Question: A space is divided by the line XY into two regions. Region I is field free and the region II has a uniform magnetic field $B = 2\text{T}$ directed into the paper. ACD is a semi-circular conducting loop of radius $r = 1\text{m}$ with centre at O , the plane of the loop being in the plane of the paper. The loop is now made to rotate with a constant angular velocity $\omega = 1\text{ rad/s}$ about an axis passing through O , and perpendicular to the plane of the paper in the clockwise direction. The effective resistance of the loop is $R = 1000\Omega$.

- (a) Find the induced current (in mA) in the loop
- (b) Show the direction of the current when the loop is entering into the region II.
- (c) Plot a graph between the induced emf and the time of rotation for two periods of rotation.

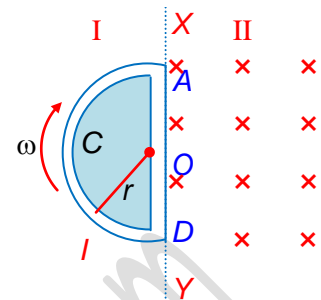

Solution: (a) As in time t , the arc swept by the loop in the field, i.e., region II,

$$S = \frac{1}{2} r^2 (\theta) = \frac{1}{2} r^2 \omega t \quad [\because \theta = \omega t]$$

So the flux linked with the rotating loop at time t ,

$$\phi = BS = \frac{1}{2} B\omega r^2 t$$

and hence the induced emf in the loop, $\epsilon = -\frac{d\phi}{dt} = -\frac{1}{2} B\omega r^2 = \text{constant}$.

and as the resistance of the loop is R , the induced current in it,

$$I = \frac{\epsilon}{R} = \frac{B\omega r^2}{2R} = 1\text{ mA}$$

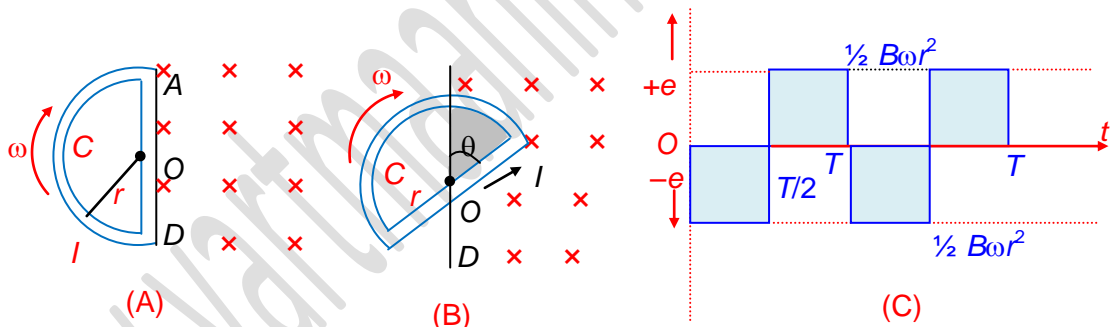

(b) When the loop is entering the region II, i.e., the field figure (b), the inward flux linked with it will increase, so in accordance with Lenz's law an anticlockwise current will be induced in it.

(c) Taking induced emf to be negative when flux linked with the loop is increasing and positive when decreasing, the emf versus time graph will be, as shown in figure (c).

Illustration 4

Question: A magnetic field perpendicular to the plane of the rectangular frame of wire is concentrated about O . If the field decreases, will there be any emf induced in loop 1 & 2?

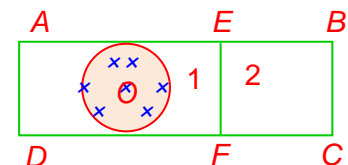

Solution: There is an induced emf in loop 1 because it encloses the field and so there is a change of flux. No emf is induced in loop 2 as it does not enclose any field.

Illustration 5

Question: Two parallel, long, straight conductors lie on a smooth plane surface. Two other parallel conductors rest on them at right angles so as to form a square of side a initially. A uniform magnetic field B exists at right angles to the plane containing the conductors. Now they start

moving out with a constant velocity (v). (a) Will the induced emf be time dependent? (b) will the current be time dependent?

Solution:

Yes, ϕ (instantaneous flux) = $B(a + 2vt)^2$

$$\therefore \epsilon = \frac{d\phi}{dt} = 4Bv(a + 2vt)$$

(b) No. i (instantaneous current) = ϵ/R

Now $R = 4(a + 2vt)r$ where r = resistance per unit length

$$\therefore i = \frac{4Bv(a + 2vt)}{4r(a + 2vt)} = \frac{Bv}{r} \text{ (a constant)}$$

Illustration 6

Question: The loops in the figure move into or out of the field which is along the inward normal to the plane of the paper. Indicate the direction of currents in loops 1, 2, 3, 4

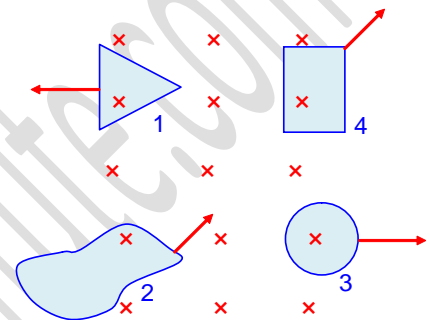

Solution:

In 1, flux decreases and so induced current must be clockwise to increase the flux. Due to the same reason currents in 3 and 4 are clockwise but in 2 current must be anticlockwise as flux is increasing.

Illustration 7

Question: A 0.4 metre long straight conductor moves in a magnetic field of magnetic induction 0.9 Wb/m² with a velocity of 0.7 m/sec. Calculate the emf induced (in mV) in the conductor under the condition when it is maximum.

Solution:

If a rod of length l is moved with velocity \vec{v} at an angle θ to the length of the rod in a field \vec{B} which is perpendicular to the plane of the motion, the flux linked with the area generated by the motion of rod in time t ,

$$\phi = Bl(v \sin \theta)t \quad \text{so, } |\epsilon| = \frac{d\phi}{dt} = Bvl \sin \theta$$

This will be maximum when $\sin \theta = \max = 1$, i.e., the rod is moving perpendicular to its length and then

$$(\epsilon)_{\max} = Bvl = 0.9 \times 0.7 \times 0.4 = 252 \times 10^{-3} \text{V}$$

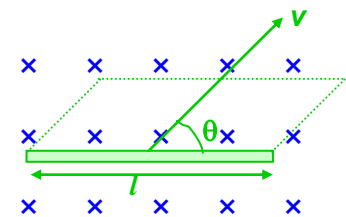
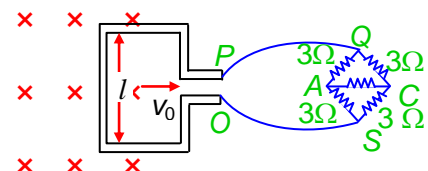

Illustration 8

Question: A square metal wire loop of side 10 cm and resistance 1 ohm is moved with a constant velocity v_0 in a uniform magnetic field of induction $B = 2$ Wb/m² as shown in figure. The magnetic field lines are perpendicular to the plane of the loop. The loop is connected to a network of resistance each of value 3 ohm. The resistances of the lead wires OS and PQ are negligible. What should be the speed of the loop so as to have a steady current of 1 milliampere in the loop? Find the direction of current in the loop?



Some important numerical problems on electromagnetic induction

Solution: As the network $AQCS$ is a balanced Wheatstone bridge, no current will flow through AC and hence the effective resistance of the network between QS ,

$$R_{QS} = \frac{6 \times 6}{6+6} = 3 \text{ ohm}$$

and as the resistance of the loop is 1 ohm, the total resistance of the circuit,
 $R = 3 + 1 = 4 \text{ ohm}$

Now if the loop moves with speed v_0 , the emf induced in the loop,
 $\epsilon = Bv_0l$

So the current in the circuit, $I = \frac{\epsilon}{R} = \frac{Bv_0l}{R}$

Substituting the given data, $v_0 = \frac{IR}{Bl} = \frac{1 \times 10^{-3} \times 4}{2 \times 0.1} = 2 \times 10^{-2} \text{ ms}^{-1} = 2 \text{ cm/s}$

In accordance with Lenz's law the induced current in the loop will be in clockwise direction.

Illustration 9

Question: Two parallel wires AL and BM placed at a distance $l = 1\text{m}$ are connected by a resistor $R = 10\Omega$ and placed in a magnetic field $B = 1\text{T}$ which is perpendicular to the plane containing the wires. Another wire CD now connects the two wires perpendicularly and made to slide with velocity $v = 10\text{m/s}$. Calculate the work done per second, needed to slide the wire CD . Neglect the resistance of all the wires.

Solution: When a rod of length l moves in a magnetic field with velocity v as shown in figure, an emf Bvl will be induced in it. Due to this induced emf, a current

$I = \frac{\epsilon}{R} = \frac{Bvl}{R}$ will flow in the circuit as shown in figure. Due to this induced current, the wire will experience a force

$$F_M = BIl = \frac{B^2 l^2 v}{R}$$

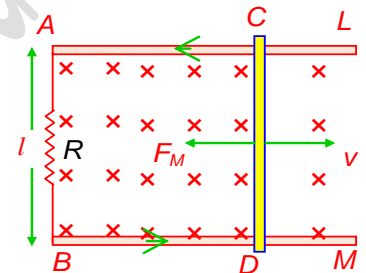

which will oppose its motion. So to maintain the motion of the wire CD a force $F = F_M$ must be applied in the direction of motion, and so the work done per second, i.e., power needed to slide the

wire, $P = \frac{dW}{dt} = Fv = F_M v = \frac{B^2 v^2 l^2}{R} = 10 \text{ W}$

Illustration 10

Question: A thin, non-conducting ring of mass $m = 1 \text{ kg}$ carrying a charge $q = 1\text{C}$ can rotate freely about its axis. At the instant $t = 0$ the ring was at rest and no magnetic field was present. Then suddenly a magnetic field $B = 2\text{T}$ was set perpendicular to the plane. Find the angular velocity acquired by the ring.

Solution: Due to the sudden change of flux an electric field is set up and the ring experiences an impulsive torque and suddenly acquires an angular velocity.

$$\epsilon \text{ (induced emf)} = -\frac{d\phi}{dt} = -\frac{d}{dt} \int \vec{B} \cdot d\vec{s}$$

Also $\epsilon = \oint \vec{E} \cdot d\vec{l}$ where E is the induced electric field.

$$\therefore \oint \vec{E} \cdot d\vec{l} = \frac{d}{dt} \int \vec{B} \cdot d\vec{s} \Rightarrow E \cdot 2\pi r = \frac{d}{dt} (B\pi r^2)$$

$$\Rightarrow E = -\frac{r}{2} \frac{dB}{dt}$$

Force experienced $= q |\vec{E}|$

torque experienced $\tau = (qE) r = \frac{qr^2}{2} \frac{dB}{dt}$

\therefore angular impulse experienced

$$= \int \tau dt = \frac{qr^2}{2} \int \frac{dB}{dt} dt = qr^2 \frac{B}{2}$$

Also angular impulse acquired = $I\omega$ where I is moment of inertia of the ring about its axis = mr^2
 $\therefore mr^2\omega = qr^2B/2 \Rightarrow \omega = qB/2m = 1 \text{ rad/s}$

PROFICIENCY TEST

The following questions deal with the basic concepts of this section. Answer the following briefly. Go to the next section only if your score is at least 80%. Do not consult the Study Material while attempting these questions.

1. If conductor is moved normally and into the plane of the paper. Which of the points A or B is at a higher potential?

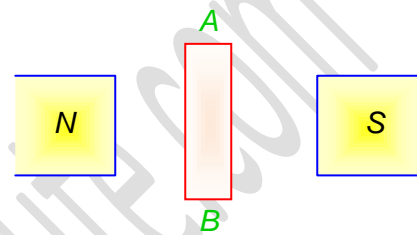

2. A current from A to B is increasing in magnitude. What is the direction of the induced current in the loop shown in the Figure?

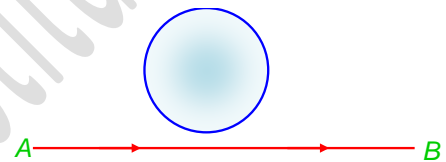

3. A wire frame $ABCD$ rotates about a long straight conductor XY carrying a current I so that the conductor XY is a stationary rotation axis. (i) Will there be any induced current in the frame? (ii) If the wire frame rotates about its side AD as axis, will there be an induced e.m.f.?

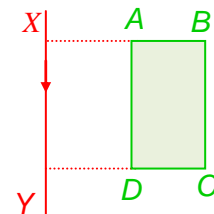

4. Two identical circular coils A and B are placed parallel to each other with their centres on the same axis. The coil B carries a current I in the clockwise direction as seen from A . What would be the direction of the induced current in A as seen from B , when
- (i) the current in B is increased?
(ii) the coil B is moved towards A keeping the current in B constant?
5. The two rails of a railway track, insulated from each other and placed on the ground are connected to a millivoltmeter. What is the reading of the millivoltmeter when a train travels at speed of 180 km/hr along the track given that the vertical component of earth's magnetic field is $0.2 \times 10^{-4} \text{ Wb/m}^2$ and the rails are separated by 1 m ?

Some important numerical problems on electromagnetic induction

6. In the Figure a conducting rod AB makes contact with metal rails AD and BC which are 50 cm apart in a uniform magnetic field of induction 1.0 T, perpendicular to the plane of the paper as shown. What is the magnitude of the induced e.m.f. in the rod when it is moved to the right with a velocity of 8 m/s?

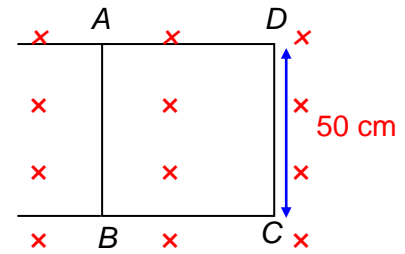

7. A solenoid has an inductance of 10 henry and a resistance of 2 ohms. It is connected to a 10 volt battery. How much magnetic energy is stored in the solenoid in steady state?
8. Two inductors of self-inductances L_1 and L_2 are connected in parallel. The inductors are so far apart that their mutual inductance is negligible. What is the equivalent inductance of the combination?
9. A primary coil is subjected to a current change of 12 A in 0.06 s. Another coil has an e.m.f. induced in it. If the mutual inductance of the two coils is 4 H, (a) what is the induced e.m.f. in the secondary coil? And (b) what is change in the flux linked in each turn of the secondary which has 1200 turns?
10. A coil has 600 turns which produces 5×10^{-2} Wb of flux when a current of 3 A flows in it. This produces a flux of 6×10^{-3} Wb in a secondary coil of 1000 turns. When a switch is opened the current drops to zero in 0.2 s. Find (a) the mutual inductance, (b) the induced e.m.f. in the secondary and (c) the self-inductance of the primary coil.

ANSWERS TO PROFICIENCY TEST

1. Point B is at a higher potential.
2. The flow of current in the straight wire along AB produces a magnetic flux through the loop towards the reader. This flux increases due to the increase in current. The induced current in the loop will therefore be in the clockwise direction to oppose the increase in flux.
3. (i) No. When the frame rotates about the conductor as the axis, there is no net change in the flux across the frame. Hence no current is induced in the frame.
(ii) Yes. An emf is induced when the frame rotates about AD .
4. (i) When the current in B is increased the flux associated with the coil A is increased. This increase in flux will induce an e.m.f. and consequently a current in A , which by Lenz's law, has a direction to oppose the increase in flux through it. The direction of the induced current in A as seen from B will be clockwise.
(ii) When the coil B is moved towards A keeping the current in B constant, this also produces an increase in the flux associated with A . Now the direction of the induced current in A will be

Some important numerical problems on electromagnetic induction

such as to oppose the increase in flux, which causes the current. Again the direction of the induced current in A as seen from B will be clockwise.

- 5. 1 mV
- 6. 4 V
- 7. 125 J
- 8. $L_{eq} = \frac{L_1 L_2}{L_1 + L_2}$
- 9. (a) 800 V
(b) 4×10^{-2} Wb
- 10. (a) 2H
(b) 30 V
(c) 10 H

SOLVED OBJECTIVE EXAMPLES

Example 1:

The magnetic flux (ϕ) in a closed circuit of resistance 20Ω varies with time (t) according to the equation $\phi = 7t^2 - 4t$ where ϕ is in weber and t is in seconds. The magnitude of the induced current at $t = 0.25$ s is

- (a) 25 mA
- (b) 0.025 mA
- (c) 47mA
- (d) 175 mA

Solution:

$$\begin{aligned} \phi &= 7t^2 - 4t \\ \Rightarrow \text{Induced emf : } |e| &= \frac{d\phi}{dt} = 14t - 4 \\ \Rightarrow \text{Induced current : } i &= \frac{|e|}{R} = \frac{|14t-4|}{20} = \frac{|14 \times 0.25 - 4|}{20} \text{ (at } t = 0.25 \text{ s)} \\ &= \frac{0.5}{20} = 2.5 \times 10^{-2} \text{ A} \\ \therefore & \text{ (a)} \end{aligned}$$

Example 2:

A train is moving from south to north with a velocity of 90 km/h. The vertical component of earth's magnetic induction is 0.4×10^{-4} Wb/m². If the distance between the two rails is 1 m, what is the induced e.m.f. in its axle?

- (a) 1 mV
- (b) 0.1 mV
- (c) 10 mV
- (d) 100 mV

Solution:

$$\text{Induced emf} = Blv = 0.4 \times 10^{-4} \times 1 \times \left(90 \times \frac{5}{18}\right) = 10^{-3} \text{ V} = 1 \text{ mV}$$

Example 3:

The square coil shown has a side of 30 cm and 20 turns of wire on it. It is moving to the right at a speed of 3 m/s as shown, inside a magnetic field whose left boundary is KL . The induced e.m.f. and the direction of induced current in

Some important numerical problems on electromagnetic induction

the coil

- (A) at the instant shown and
 (B) when the coil is completely inside the field region are given by
- (a) 7.2 V, anticlockwise (b) 7.2 V, clockwise
 (b) 7.2 V, clockwise (b) 7.2 V, anticlockwise
 (c) 7.2 V, anticlockwise (b) zero
 (d) 7.2 V, clockwise (b) zero

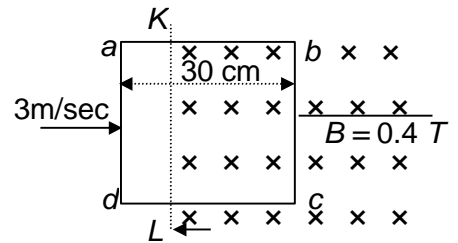

Solution:

- (a) Induced emf = $nBlv = 20 \times 0.4 \times 0.3 \times 3 = 7.2 \text{ V}$
 By Fleming's right hand rule, direction of current is from *c* to *b* (anticlockwise).
 (b) When the coil is fully inside the field, emfs induced along *cb* and *da* cancel out.
 \therefore (c)

Example 4:

A thin semicircular conducting ring of radius *R* is falling with its plane vertical in a horizontal magnetic induction *B* (See the figure). At the position *MNQ* the speed of the ring is *V* and the potential difference developed across the ring is

- (a) zero
 (b) $BV/\pi R^2/2$ and *M* is at higher potential
 (c) πRBV and *Q* is at higher potential
 (d) $2RBV$ and *Q* is at higher potential

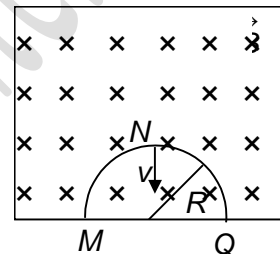

Solution:

- Emf induced in the ring = BVl , where *l* = projection of length at right angles to $\vec{B} \Rightarrow l = MQ = 2R$.
 Therefore *Q* will be at a higher potential.
 \therefore (d)

Example 5:

Two concentric coplanar circular loops have diameters 20 cm and 2 m and resistance of unit length of the wire = $10^{-4} \Omega/\text{m}$. A time-dependent voltage $V = (4 + 2.5t)$ volts is applied to the larger as shown. The current in the smaller loop is

- (a) 0.5 A (b) 0.75 A
 (c) 1 A (d) 1.25 A

Solution:

$r_1 = 1.0 \text{ m}, r_2 = 10^{-1} \text{ m}$
 Resistance of outer loop = $2\pi \times 10^{-4} \Omega$
 Resistance of inner loop = $0.2\pi \times 10^{-4} \Omega$
 Current in outer loop = $\frac{V}{R} = \frac{(4+2.5t)}{2\pi \times 10^{-4}} \text{ A}$

or $i_0 = \left[\left(\frac{2}{\pi} \right) \times 10^4 + \left(\frac{1.25}{\pi} \right) \times 10^4 \times t \right] \text{ A}$

Magnetic field produced at the common centre (see figure)

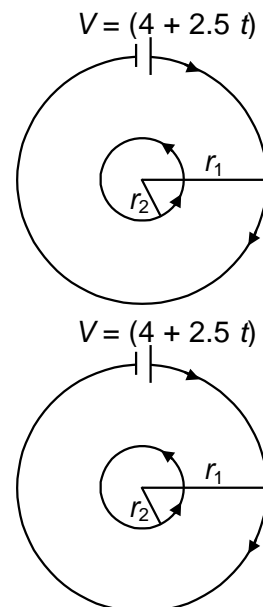

Some important numerical problems on electromagnetic induction

$$B = \frac{\mu_0 i}{2r_1} = \left(\frac{\mu_0 i}{2} \right) T$$

or $B = \frac{4\pi}{2} \times 10^{-7} \times \frac{[(2+1.25t)10^4]}{\pi} = 2 \times 10^{-3} (2 + 1.25 t) T$

Hence, flux linked with the inner loop,

$$\phi = BA = 2 \times 10^{-3} (2 + 1.25 t) \times \pi (0.1)^2 = 2\pi \times 10^{-5} (2 + 1.25 t) \text{ Wb.}$$

Hence, e.m.f. induced in smaller loop $= \varepsilon = - \frac{d\phi}{dt} = - 2\pi \times 10^{-5} \times 1.25$

$$= - 2.5 \pi \times 10^{-5} \text{ V.}$$

The negative sign indicates that the induced e.m.f. (or current) is opposite to applied e.m.f. (or current).

Hence, the current induced in the inner (smaller) loop is

$$= \frac{|\varepsilon|}{R} = \frac{2.5\pi \times 10^{-5} \text{ V}}{(0.2\pi \times 10^{-4}) \Omega} = 1.25 \text{ A.}$$

∴ (d)

Example 6:

A rectangular wire frame of length 0.2m, is located at a distance of $5 \times 10^{-2} \text{ m}$ from a long straight wire carrying a current of 10 A as shown in the Figure. The width of the frame = 0.05 m. The wire is in the plane of the rectangle. Find the magnetic flux through the rectangular circuit. If the current decays uniformly to 0 in 0.02 s, find the emf induced in the circuit.

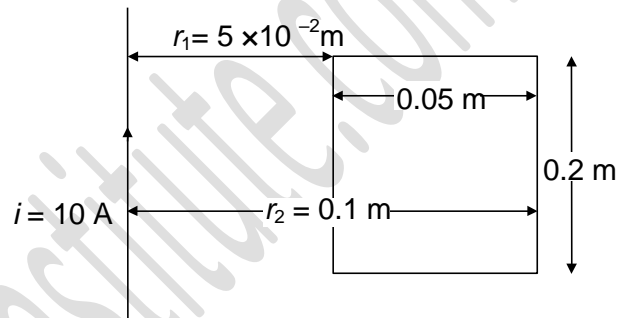

- (a) $2.772 \times 10^{-7} \text{ Wb}$, $13.86 \mu\text{V}$
- (b) $4.962 \times 10^{-7} \text{ Wb}$, $6.85 \mu\text{V}$
- (c) $6.385 \times 10^{-7} \text{ Wb}$, $3.423 \mu\text{V}$
- (d) $8.495 \times 10^{-7} \text{ Wb}$, $1.245 \mu\text{V}$

Solution:

A current, $i = 10 \text{ A}$ is flowing in the long straight wire. Consider a small rectangular strip (in the rectangular wire frame) of width dx at a distance x from the straight wire. The magnetic flux at the

location of the strip, $B_x = \frac{\mu_0 i}{2\pi x}$

The flux linked with the infinitesimally small rectangular strip

$$= B_x \times \text{Area of the strip} = d\phi_x = \frac{\mu_0 i}{2\pi x} l dx$$

where $l =$ length of the rectangular wire circuit $= 2 \times 10^{-1} \text{ m}$.

or $d\phi_x = (\mu_0 i l / 2\pi) (dx/x)$.

Hence, total magnetic flux linked with the rectangular frame

$$\phi = \int d\phi_x = \frac{\mu_0 i l}{2\pi} [\log_e x]_{r_1}^{r_2} \text{ or } \phi = \frac{\mu_0 i l}{2\pi} (\log_e r_2 - \log_e r_1) = \frac{\mu_0 i l}{2\pi} \log_e \left(\frac{r_2}{r_1} \right)$$

Substituting values, we get

$$\phi = 2 \times 10^{-7} \times 10 \times 2 \times 10^{-1} \log_e 2 = 2.772 \times 10^{-7} \text{ Wb}$$

Induced e.m.f. $|\varepsilon| = \frac{d\phi}{dt} = \frac{\mu_0 i l \log_e \left(\frac{r_2}{r_1} \right)}{2\pi} \frac{di}{dt} = 2.772 \times 10^{-8} \left(\frac{10}{2} \times 10^{-2} \text{ s} \right) = 13.86 \times 10^{-6}$

∴ (a)

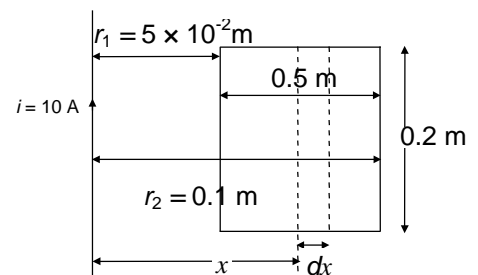

Example 7:

A copper rod of length $l = 25 \text{ cm}$ rotates with constant angular velocity $\omega = 10\pi \text{ rad/s}$ in a uniform magnetic field of induction, $B = 2 \text{ T}$. \vec{B} is perpendicular to the length of the rod. The emf developed between the two ends of the rod is

Some important numerical problems on electromagnetic induction

(a) 1 V

(b) 2 V

(c) 3 V

(d) 4 V

Solution:

The copper rod rotates in a circle of radius l , (the plane of rotation is perpendicular to B) with an angular velocity ω . Let us consider a small length of the rod, dx , at a distance, x from the centre C . If v is the linear velocity (i.e. along the tangent to the circle) of the element, then the element covers an area

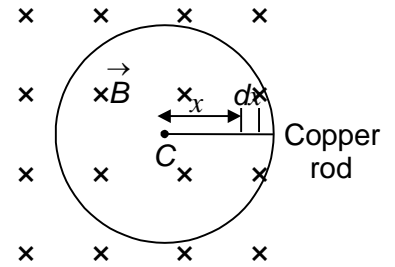

$$dA = (v dt) \times dx \text{ in a time } dt, \text{ or } \frac{dA}{dt} = v dx = x\omega dx.$$

Now, $\phi = BA$ and e.m.f. = $-\frac{d\phi}{dt} = -B\left(\frac{dA}{dt}\right) = -Bx\omega dx$.

If we consider the whole rod of length l , the induced e.m.f.

$$\epsilon = \int_0^l Bx\omega dx = B\omega \frac{l^2}{2}$$

Now, substituting the values, we get

$$\epsilon = (2.0 T) \times (10 \pi) \frac{(0.25)^2}{2} = \left(\frac{10\pi}{16}\right) \Rightarrow \epsilon \approx 2.0 \text{ V.}$$

\therefore (b)

Example 8:

A non-conducting ring of radius r has a charge Q uniformly distributed over it. A magnetic field perpendicular to the plane of the ring changes at the rate $\frac{dB}{dt}$. The torque experienced by ring is

(a) zero

(b) $Qr^2 \frac{dB}{dt}$

(c) $\frac{1}{2} Qr^2 \frac{dB}{dt}$

(d) $\pi r^2 Q \frac{dB}{dt}$

Solution:

The same e.m.f. is induced in a conducting and non-conducting ring. It is equal to $\pi r^2 \frac{dB}{dt}$. At any point on

the ring, $E = \frac{1}{2} r \frac{dB}{dt}$. For any charge dQ on the ring, the force $dF = EdQ$ tangential to ring.

Torque about centre due to $dF = d\tau = r dF = rEdQ$.

$$\text{Total torque} = \Sigma rEdQ = r \cdot \frac{1}{2} r \frac{dB}{dt} Q = \frac{1}{2} r^2 Q \frac{dB}{dt}$$

\therefore (c)

Example 9:

A uniformly wound solenoidal coil of self-inductance $1.8 \times 10^{-4} \text{ H}$ and resistance 6Ω is broken into two identical coils. These induction coils are then connected in parallel across a 12 V battery of negligible resistance. The time constant of the circuit is

(a) $\frac{3}{2} \times 10^{-5} \text{ s}$

(b) $2 \times 10^{-5} \text{ s}$

(c) $\frac{20}{3} \times 10^{-4} \text{ s}$

(d) $3 \times 10^{-5} \text{ s}$

Solution:

The inductance of the circuit (L) is given by

$$\frac{1}{L} = \frac{1}{L_1} + \frac{1}{L_2}, \text{ where } L_1 = L_2 = \frac{1.8}{2} \times 10^{-4} \text{ H}$$

$$\Rightarrow L = \frac{L_1}{2} = \frac{1.8}{4} \times 10^{-4} \text{ H}$$

Similarly, resistance of the circuit : $R = \frac{6}{4} \Omega = 1.5 \Omega$

\therefore time constant : $\tau = \frac{L}{R} = \frac{1.8 \times 10^{-4}}{6} = 3 \times 10^{-5} \text{ sec}$

\therefore (d)

SOLVED SUBJECTIVE EXAMPLES

Example 1:

A circular coil of radius 5 cm consists of exactly 250 turns. A magnetic field is directed perpendicular to its plane, as shown in the figure. It is increasing at a rate of 0.6 T/s. If the resistance of the coil is 8Ω , find the current induced (in mA) in the coil.

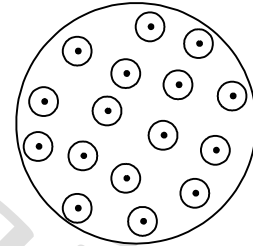

Solution:

$$\text{Induced emf } |e| = N \left| \frac{d\phi_B}{dt} \right| = N \pi R^2 \frac{dB}{dt}$$

$$\frac{dB}{dt} = +0.6 \text{ T/s}$$

$$\therefore |e| = (250) \times \pi \times (5 \times 10^{-2})^2 (0.6) = 1.18 \text{ V}$$

$$\therefore \text{ induced current (in mA)} = \frac{e}{R} = 147$$

Example 2:

A circular loop of area $A = 0.1 \text{ m}^2$ and resistance $R = 10 \Omega$ rotates with an angular velocity $\omega = 1 \text{ rad/s}$ about an axis through its diameter as shown in figure. The plane of the loop is initially perpendicular to a constant magnetic field B . $B = 0.1 \text{ T}$. Find the amplitude of the induced current (in mA) in the loop

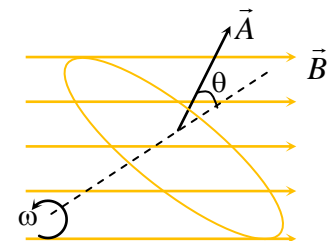

Solution:

The instantaneous magnetic flux through the loop is

$$\Phi_B = BA \cos \theta$$

Since, $\theta = \omega t$, therefore, $\Phi_B = BA \cos \omega t$

From Faraday's law, equation

$$e = - \frac{d\Phi_B}{dt} = - \frac{d}{dt} [BA \cos \omega t] \text{ or } e = BA \omega \sin \omega t$$

The induced current is $I = \frac{e}{R} = \left(\frac{BA \omega}{R} \right) \sin \omega t$

The amplitude of induced current (in mA) = $\frac{BA \omega}{R} = 1$

Example 3:

Some important numerical problems on electromagnetic induction

Two long parallel wires carrying current I are separated by a distance $3a = 3\text{m}$. There exists a square loop of side $a = 1\text{m}$ with a capacitor of capacity $C = 1\text{mF}$ as shown in figure. The value of current varies with time as $I = I_0 \sin \omega t = 10 \sin(0.5t)\text{A}$. Calculate maximum current (in μA) in the square loop.

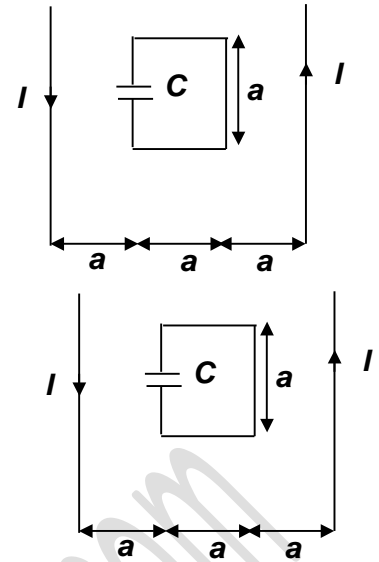

Solution:

(a) $I = I_0 \sin \omega t$

Flux linked with square loop $\int d\phi = \int_a^{2a} \frac{\mu_0 I}{2\pi} \left[\frac{1}{x} + \frac{1}{3a-x} \right] a dx$

$= \frac{\mu_0 I a}{2\pi} [\ln x - \ln(3a-x)]_a^{2a}$

$= \frac{\mu_0 I a}{2\pi} [\ln 2a - \ln a - \ln a + \ln 2a]$

$= \frac{\mu_0 I a}{2\pi} 2 \ln 2 = \frac{\mu_0 I a}{\pi} \ln 2$

Charge on capacitor $= \left| C \frac{d\phi}{dt} \right| = C \frac{\mu_0 a}{\pi} \ln 2 \frac{dI}{dt}$

$= \frac{\mu_0 C a}{\pi} \ln 2 (I_0 \omega) \cos \omega t$... (i)

$= \frac{\mu_0 C (I_0 \omega) a}{\pi} \ln 2 \cos \omega t$... (ii)

Maximum current I (in μA) $= \left| \frac{dq}{dt} \right|_{\text{max}} = \frac{\mu_0 C I_0 \omega^2 a}{\pi} \ln 2 = 693$

Example 4:

The Figure shows a conductor of length $l = 0.5\text{m}$ and resistance $r = 0.5\text{ohm}$ sliding without friction at a velocity $v = 2\text{m/s}$ over two conducting parallel rods ab and cd lying in a horizontal plane. A resistance $R = 2.5\ \Omega$ connects the ends b and c . A vertical uniform magnetic field of induction $B = 6\text{T}$ exists over the region. Determine (i) the current in the circuit, (ii) the force in the direction of motion to be applied to the conductor for the latter to move with the velocity v and (iii) the thermal power dissipated by the circuit. Neglect the resistance of the guiding rods ab and cd .

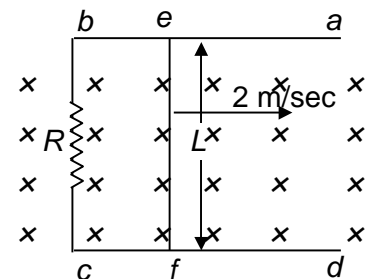

Solution:

The conductor ef moves with a velocity v perpendicular to a uniform magnetic induction B and hence induces an e.m.f. $E = Blv$.

The resistance of the circuit $= (R + r)$

(i) Hence the current in the circuit $= \frac{Blv}{R+r} = \frac{(6)(0.5)(2)}{(2.5+0.5)} = 2\text{A}$

(ii) The power spend in the system $F.v = \frac{(Blv)^2}{(R+r)}$

$F = \frac{B^2 l^2 v}{R+r} = 6\text{N}$

A force of 6N is required to maintain the motion of the conductor

Some important numerical problems on electromagnetic induction

(ii) The power generated $F.V = \frac{(Blv)^2}{(R+r)} = 12 \text{ W}$

Example 5:

A conductor ab of length $l = 0.4 \text{ m}$ and with a resistance $r = 0.6 \Omega$ moves along conducting guides cd and ef with a uniform speed of $v = 5 \text{ m/s}$ normal to a uniform magnetic field of induction $B = 3 \text{ T}$. The guides are short circuited with resistances $R_1 = 6 \Omega$ and $R_2 = 4 \Omega$ as shown.

Determine (i) the current through the conductor ab , (ii) the mechanical power needed for the motion of the conductor ab . Ignore the resistance and the friction of the guides.

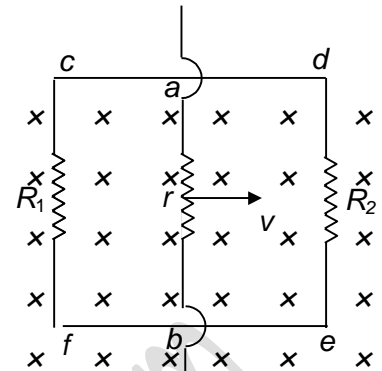

Solution:

The e.m.f. induced in the conductor ab

$$E = Blv = (3\text{T})(0.4 \text{ m})(5\text{m/s}) = 6 \text{ volt}$$

The conductor ab can now be taken as a voltage source with an internal resistance $r = 0.6 \text{ ohm}$ while two resistors $R_1 = 6 \text{ ohm}$ and $R_2 = 4 \text{ ohm}$ are connected in parallel with it.

Hence the total resistance of the circuit

$$= \frac{6 \times 4}{6 + 4} + 0.6 \Omega = 3 \Omega$$

(i) The current through the conductor

$$ab = \frac{0.6V}{3\Omega} = 2 \text{ A}$$

(ii) The mechanical power needed for the motion of the conductor

$$ab = \frac{E^2}{R} = \frac{(6)^2}{3} \text{ watt} = 12 \text{ W}$$

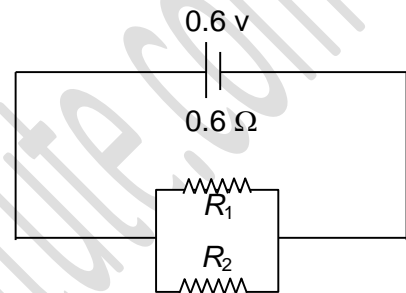

Example 6:

A coil ACD of $n = 2$ turns and radius $R = 1\text{m}$ carries a current $I = 1 \text{ amp}$ and is placed on a horizontal table. K is a small conducting ring of radius $r = 1\text{cm}$ placed at a distance $y_0 = 6\text{m}$ from the centre of and vertically above the coil ACD . Find the e.m.f. established (in nV) at $t = 1\text{s}$ after the ring K is allowed to fall freely. ($\pi^2 \approx 10$)

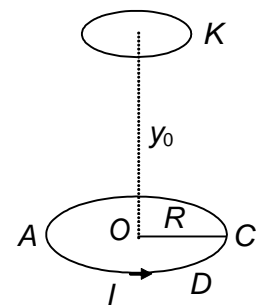

Solution:

The field along the axis of the coil ACD is given by $\frac{\mu_0}{4\pi} \frac{2\pi n I R^2}{(R^2 + y^2)^{3/2}}$

Since the ring is small it may be assumed that the induction through it is uniform and is equal to that on the axis.

$$\therefore \text{the magnetic flux linked with it is } \phi = BA = \frac{\mu_0}{4\pi} \frac{2\pi n I R^2}{(R^2 + y^2)^{3/2}} \times \pi r^2 = \frac{\mu_0}{2} \frac{\pi n I R^2 r^2}{(R^2 + y^2)^{3/2}}$$

Here y varies as $y = y_0 - \frac{1}{2}gt^2$, where by $\frac{dy}{dt} = -gt = -v$

where v is the instantaneous velocity of fall.

The induced e.m.f in the ring is given by

Some important numerical problems on electromagnetic induction

$$\begin{aligned}
 E &= \frac{d\phi}{dt} = \frac{\mu_0}{2} \pi n I R^2 r^2 \cdot \frac{d}{dt} (R^2 + y^2)^{-3/2} \\
 &= -\frac{3}{4} \mu_0 \pi n I R^2 r^2 \cdot (R^2 + y^2)^{-5/2} \cdot 2y \frac{dy}{dt} \\
 &= -\frac{3}{2} \frac{\mu_0 \pi n I R^2 r^2}{(R^2 + y^2)^{5/2}} \cdot y \cdot (-v) \\
 &= \frac{3}{2} \frac{\mu_0 \pi R^2 r^2 n I}{(R^2 + y^2)^{5/2}} y v = 12
 \end{aligned}$$

Example 7:

An infinitesimally small bar magnet of dipole moment $M = 1 \text{ A}\cdot\text{m}^2$ is pointing and moving with the speed $v = 1 \text{ m/s}$ in the x -direction. A small closed circular conducting loop of radius $a = 1 \text{ cm}$ and of negligible self-inductance lies in the y - z plane with its centre at $x = 0$, and its axis coinciding with the x -axis. The force opposing the motion of the magnet when $x = 1 \text{ m}$ is found to be $y \times 10^{-22} \text{ N}$. The resistance of the loop $R = 10 \Omega$. Find the value of y .

Solution:

Field due to the bar magnet at distance x (near the loop)

$$B = \frac{\mu_0}{4\pi} \frac{2M}{x^3}$$

$$\Rightarrow \text{Flux linked with the loop : } \phi = BA = \pi a^2 \cdot \frac{\mu_0}{4\pi} \frac{2M}{x^3}$$

$$\text{Emf induced in the loop : } e = -\frac{d\phi}{dt} = \frac{\mu_0}{4\pi} \frac{6\pi M a^2}{x^4} \frac{dx}{dt} = \frac{\mu_0}{4\pi} \frac{6\pi M a^2}{x^4} v.$$

$$\Rightarrow \text{Induced current : } i = \frac{e}{R} = \frac{\mu_0}{4\pi} \frac{6\pi M a^2}{R x^4} v.$$

Let F = force opposing the motion of the magnet

Power due to the opposing force = Heat dissipated in the coil per second

$$\begin{aligned}
 \Rightarrow Fv = i^2 R \Rightarrow F &= \frac{i^2 R}{v} = \left(\frac{\mu_0}{4\pi}\right)^2 \times \left(\frac{6\pi M a^2}{R x^4}\right)^2 \times v^2 \times \frac{R}{v} \\
 &= \frac{9}{4} \left(\frac{\mu_0^2 M^2 a^4 v}{R x^8}\right) = 36 \times 10^{-22} \text{ N} \quad \therefore y = 36
 \end{aligned}$$

Example 8:

A square wire of length $l = 1 \text{ m}$ mass $m = 100 \text{ g}$ and resistance $R = 30 \Omega$ slides without friction down the parallel conducting wires of negligible resistance as shown in Figure.

The rails are connected to each-other at the bottom by a resistanceless rail parallel to the wire so that the wire and rails form a closed rectangular loop. The plane of the rails makes an angle $\theta = 30^\circ$ with horizontal and a uniform vertical field of magnetic induction $B = 1 \text{ T}$ exists throughout the region. Find the steady state velocity (in m/s) acquired by the wire.

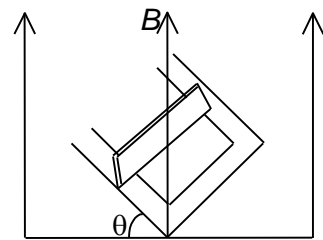

Solution:

Force down the plane = $mg \sin \theta$

At any instant if the velocity is v the induced e.m.f. = $lB \cos \theta \times v$

$$\text{Current in the loop} = \frac{lB \cos \theta v}{R}$$

Force on the conductor in the horizontal direction

$$= \frac{Bl \times B \cos \theta}{R} \times v \times l$$

$$\text{Component parallel to the incline} = \frac{B^2 l^2 \cos \theta}{R} \times v$$

Some important numerical problems on electromagnetic induction

If v is constant $\frac{B^2 l^2 \cos^2 \theta}{R} \times v = mg \sin \theta \quad \therefore \quad v = \frac{mRg \sin \theta}{B^2 l^2 \cos^2 \theta} = 10$

Example 9:

Figure shows a copper rod moving with velocity \vec{v} parallel to a long straight wire carrying a current i . Calculate the induced e.m.f. (in pV) in the rod assuming $v = 0.005$ m/s, $i = 1$ ampere, $a = 10$ cm, $b = 20$ cm.

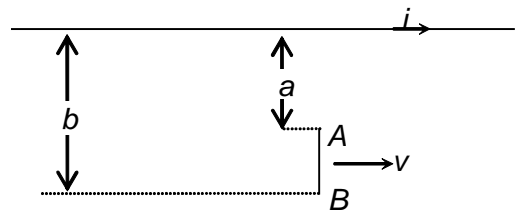

Solution:

The induction at a point whose perpendicular distance from the rod is x is given by

$$B_{(x)} = \frac{\mu_0 i}{2\pi x}$$

The e.m.f. induced (in pV) on moving the rod $= \varepsilon = v \int_{x=a}^{x=b} B_{(x)} dx = v \int_a^b \frac{\mu_0 i dx}{2\pi x}$

$$= \frac{\mu_0 i v}{2\pi} \int_a^b \frac{dx}{x} = \frac{\mu_0 i v}{2\pi} \log_e \left(\frac{b}{a} \right) = 693$$

Example 10:

The current in a coil of self inductance $L = 2\text{H}$ is increasing according to the law $i = 2 \sin t^2$. Find the amount of energy spent during the period when the current changes from 0 to 2 ampere.

Solution:

Let the current be 2 amp at $t = \tau$.

$$\text{Then } 2 = 2 \sin \tau^2 \Rightarrow \tau = \sqrt{\frac{\pi}{2}}$$

When the instantaneous current is i , the self induced emf is $L \frac{di}{dt}$. If dq amount of charge is displaced in time

$$dt \text{ then elementary work done } = L \left(\frac{di}{dt} \right) dq = L \frac{di}{dt} i dt = Li di$$

$$W = \int_0^\tau L i di = \int_0^\tau L 2 \sin t^2 d(2 \sin t^2)$$

$$W = \int_0^\tau 8L \sin t^2 \cos t^2 t dt = 4L \int_0^\tau \sin 2t^2 t dt$$

$$\text{Let } \theta = 2t^2 \quad d\theta = 4t dt$$

$$\therefore \text{ the integral } = 4L \int \frac{\sin \theta d\theta}{4}$$

$$= L (-\cos \theta)$$

$$= -L \cos 2t^2$$

$$W = -L [\cos 2t^2]_0^{\sqrt{\pi/2}}$$

$$= 2L = 2 \times 2 = 4 \text{ Joules}$$

MIND MAP

1. Magnetic flux

$\phi = B.A \cos \theta$
It can be changed by changing B , A or θ with time

2. Faraday's law:

The emf induced in a

www.vartmaaninstitute.com
numerical problems on electromagnetic induction

3. Lenz's law: effect of the induced emf is such as to oppose the change in flux that produces it.

4. Motional Emf:

Emf induced across a conductor of length l

**ELECTROMAGNETIC
INDUCTION**

5. (a) Self induction

$$\phi = Li$$

$$\varepsilon = -L \frac{di}{dt}$$

where L is called self inductance of the coil

(b) Mutual induction

$$\phi = Mi$$

$$\varepsilon = -M \frac{di}{dt}$$

Mutual inductance of pair of solenoids

$$M = \frac{\mu_0 N_1 N_2 \pi R_1^2}{l_1}$$

(c) Energy stored in an inductor

$$E = \frac{1}{2} Li^2$$

(d) Grouping of inductors

(i) In series combination

$$L = L_1 + L_2 + L_3 \dots$$

(ii) In parallel combination

$$\frac{1}{L} = \frac{1}{L_1} + \frac{1}{L_2} + \frac{1}{L_3} \dots$$

EXERCISE – I

NEET-SINGLE CHOICE CORRECT

Some important numerical problems on electromagnetic induction

1. A conductor rod AB moves parallel to positive x -axis in a uniform magnetic field (along positive z -axis) as shown. The end A of the rod gets
- (a) positively charged
 - (b) negatively charged
 - (c) neutral
 - (d) first positively charged and then negatively charged

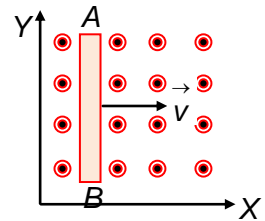

2. A conductor rotating with constant angular velocity ω inside a magnetic field B as shown. Which of the following represents the distribution of charge on conductor at that instant.

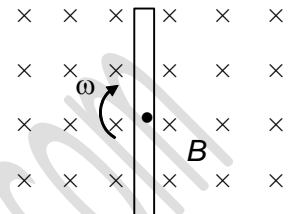

3. In the given figure a conducting rod is held between the poles of a permanent magnet. An electric potential difference will be induced between the ends of the conductor when it is moved in the direction of
- (a) P
 - (b) Q
 - (c) L
 - (d) M

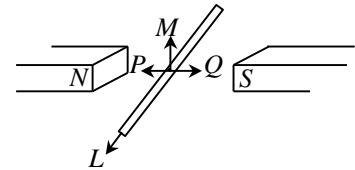

4. A magnet is moving towards a coil along its axis and the emf induced in the coil is ϵ . If the coil also starts moving towards the magnet with the same speed, the induced emf will be
- (a) $\epsilon/2$
 - (b) ϵ
 - (c) 2ϵ
 - (d) 4ϵ
5. A coil having 500 square loops, each of side 10 cm, is placed normal to a magnetic field which is increasing at the rate of 1.0 tesla per second. The induced emf is
- (a) 0.1 V
 - (b) 0.5 V
 - (c) 1 V
 - (d) 5 V
6. A rectangular coil of 100 turns and size 0.1 m \times 0.05 m is placed perpendicular to a magnetic field of 0.1 T. If the field drops to 0.05 T in 0.05 s, the magnitude of the emf induced in the coil is
- (a) 0.5 V
 - (b) 0.75 V
 - (c) 1.0 V
 - (d) 1.5 V
7. A wire of length 1.0 m moves with a speed of 10 m/s perpendicular to a magnetic field. If the emf induced in the wire is 1.0 V, the magnitude of the field is
- (a) 0.01 T
 - (b) 0.1 T
 - (c) 0.2 T
 - (d) 0.02 T
8. A coil of cross sectional area 400 cm² having 30 turns is making 1800 rev/min in a magnetic field of 1 T. The peak value of the induced emf is

Some important numerical problems on electromagnetic induction

- (a) 113 V (b) 226 V (c) 339 V (d) 452 V

9. A coil is rotated in a uniform magnetic field about an axis perpendicular to the field. The emf induced in the coil would be maximum when the plane of the coil is
- (a) parallel to the field (b) perpendicular to the field
(c) at 45° to the field (d) in none of the above positions

10. A coil of area 80 cm^2 and 50 turns is rotating with 2000 revolutions per minute about an axis perpendicular to a magnetic field of 0.05 T. The maximum value of emf developed in it is
- (a) $2000 \pi \text{ V}$ (b) $\frac{10\pi}{3}$ (c) $\frac{4\pi}{3} \text{ V}$ (d) $\frac{2}{3} \text{ V}$

11. The wings of an aeroplane are 10 m apart. The plane is moving horizontally towards the north with a velocity of 200 m/s at a place where the vertical component of earth's magnetic field is $0.5 \times 10^{-4} \text{ T}$. The induced emf set up between the ends of the wings is
- (a) 0.1 V (b) 0.15 V (c) 1 V (d) 1.5 V

12. A uniform but increasing with time magnetic field exists in a circular region perpendicular to its plane as shown in figure. The direction of force on an electron at P is

- (a) towards right
(b) towards left
(c) into the plane of paper
(d) out of the plane of paper

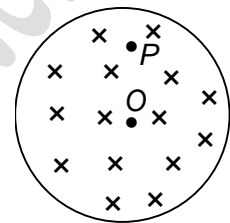

13. A uniform but time-varying magnetic field $B(t)$ exists in a circular region of radius a and is directed in to the plane of the paper as shown. the magnitude of the induced electric field at the point P at a distance r from the center of the circular region
- (a) is zero (b) decreases as $1/r$
(c) increases as r (d) decreases as $1/r^2$

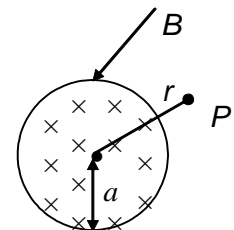

14. A coil area $A = 0.5 \text{ m}^2$ is situated in a uniform magnetic field $B = 4 \text{ Wb/m}^2$ and makes an angle of 60° with respect to the magnetic field as shown. The value of the magnetic flux through the area A would be equal to

- (a) 2 weber (b) 1 weber (c) 3 weber (d) $(3/2)$ weber

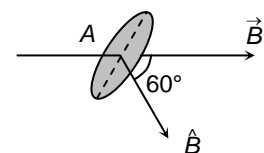

15. Lenz's law is a consequence of the law of conservation of
- (a) charge (b) mass (c) momentum (d) energy
16. A copper ring is held horizontally and a bar magnet is dropped through the ring with its length along the axis of the ring. The acceleration of the falling magnet is
- (a) equal to that due to gravity
(b) less than that due to gravity

Some important numerical problems on electromagnetic induction

- (c) more than that due to gravity
- (d) depends on the diameter of the ring and the length of the magnet

17. A copper ring having a cut such as not to form a complete loop is held horizontally and bar magnet is dropped through the ring with its length along the axis of the ring. The acceleration of the falling magnet is
- (a) g
 - (b) less than g
 - (c) more than g
 - (d) depends on the relative size of the cut

18. The mutual inductance of a pair of coils, each of N turns, is M henry. If a current of I ampere in one of the coils is brought to zero in t seconds, the average induced emf in the other coil, in volt, will be

- (a) $\frac{MI}{t}$
- (b) $\frac{NMI}{t}$
- (c) $\frac{MN}{It}$
- (d) $\frac{MI}{Nt}$

19. An emf of 5 mV is induced in a coil when, in a nearby placed another coil, the current changes by 5 A in 0.1 s. The mutual inductance between the two coils will be

- (a) 1 H
- (b) 0.1 H
- (c) 0.1 mH
- (d) 0.001 mH

20. A conducting rod is rotated in a plane perpendicular to a uniform magnetic field with constant angular velocity. The correct graph between the induced emf (ϵ) across the rod and time (t) is

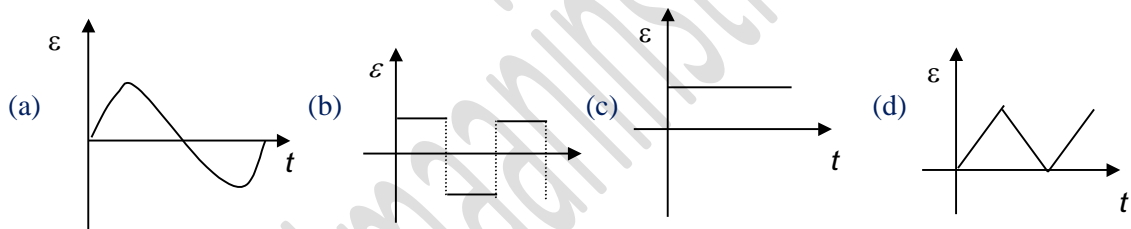

21. In the given circuit, the potential difference between point P and Q in steady state is

- (a) 40 V
- (b) 21 V
- (c) 18 V
- (d) 18 V

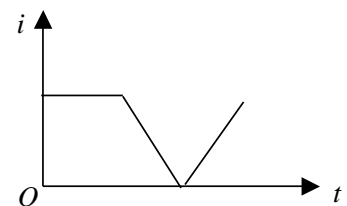
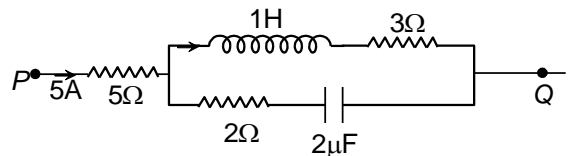

22. The current i in an induction coil varies with time t according to the graph shown in the figure. Which of the following graphs shows the induced emf ϵ in the coil with time

Some important numerical problems on electromagnetic induction

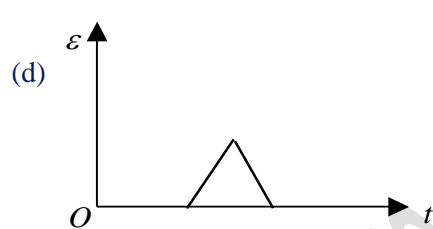
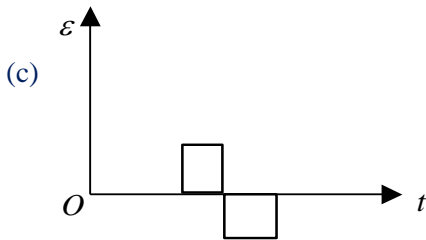
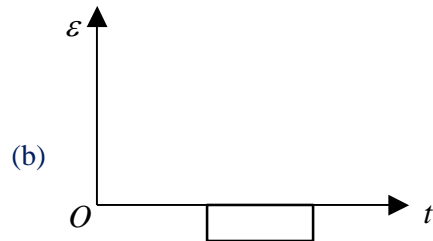
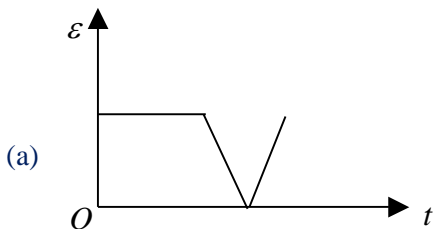

23. Shown in the figure is a circular loop of radius r and resistance R . A variable magnetic field of inductance $B = B_0 e^{-t}$ is established inside the coil. If the key (K) is closed, the electrical power developed right after closing the switch is equal to

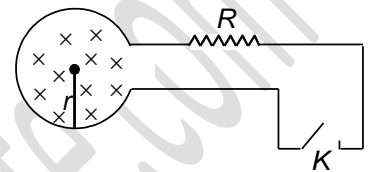

- (a) $\frac{B_0^2 \pi r^2}{R}$ (b) $\frac{10 B_0 r^3}{R}$ (c) $\frac{B_0^2 \pi^2 r^4 R}{5}$ (d) $\frac{B_0^2 \pi^2 r^4}{R}$

24. A rectangular loop with a sliding connector of length 10 cm is situated in a uniform magnetic field perpendicular to plane of loop. The magnetic induction is 0.1T and resistance of connector (R) is 1 ohm. The side AB and CD have resistances 2 ohm and 3 ohm respectively. Find the current in connector during its motion with constant velocity one meter/sec

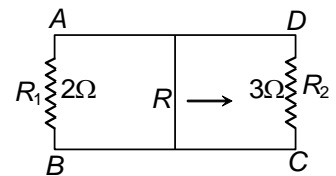

- (a) $\frac{1}{220} A$ (b) $\frac{1}{110} A$ (c) $\frac{1}{440} A$ (d) $\frac{1}{55} A$

25. Two circular loops P and Q are placed with their planes parallel to each other. A current is flowing through P . If this current is increased, then
- (a) the loops will attract each other
 (b) the loops will repel each other
 (c) the loops will neither attract nor repel each other
 (d) loop Q will start moving

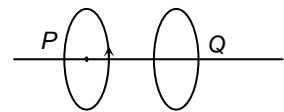

EXERCISE – II

IIT-JEE- SINGLE CHOICE CORRECT

Some important numerical problems on electromagnetic induction

1. A conducting rod is rotated by means of strings in a uniform magnetic field with constant angular velocity as shown in the figure. Potential of points A , B and C are V_A , V_B and V_C respectively. Then

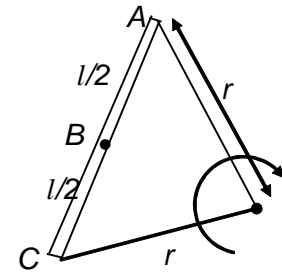

- (a) $V_A > V_B > V_C$
 (b) $V_A = V_B = V_C$
 (c) $V_A = V_C > V_B$
 (d) $V_A = V_C < V_B$

2. A wire is bent in form of a V shape and placed in a horizontal plane. There exist a uniform magnetic field B perpendicular to the plane of the wire. A uniform conducting rod starts sliding over the V shaped wire with a constant speed v as shown in the figure. If the wire has no resistance, the current in the rod will

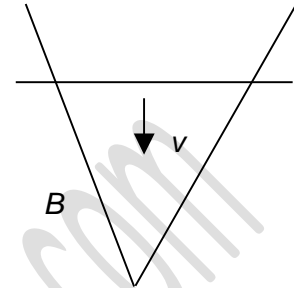

- (a) increase with time
 (b) decrease with time
 (c) remain constant
 (d) always be zero

3. A square loop $ABCD$ of side l is placed as shown in the figure with point A lying at origin. A magnetic field $B = -B_0 \hat{k}$ exists in the space. What is change in flux $|\Delta\Phi|$ when the loop is rotated through an angle 180° about CD (as shown in the figure)

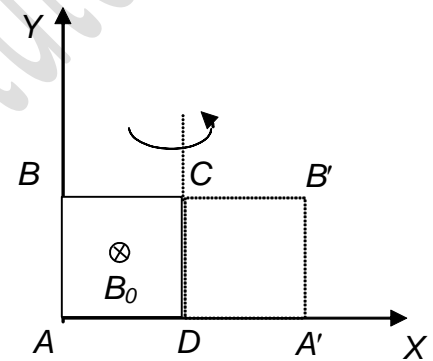

- (a) zero
 (b) $2l^2B_0$
 (c) $3l^2B_0$
 (d) l^2B_0

4. The long straight wire AB in the figure carries a current I . The total flux through the rectangle $CDEF$ is

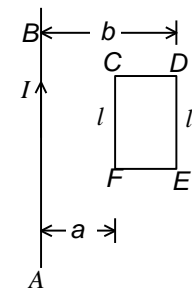

- (a) $\frac{\mu_0 I l}{2\pi} \log_e \frac{b}{a}$
 (b) $\frac{\mu_0 I a}{2\pi b}$
 (c) $\frac{\mu_0 I b}{2\pi a}$
 (d) $\frac{\mu_0 I l}{2\pi ab}$

5. A square loop of side b is rotated in a constant magnetic field B with an angular frequency ω as shown in the figure. What is the *emf* induced in it?

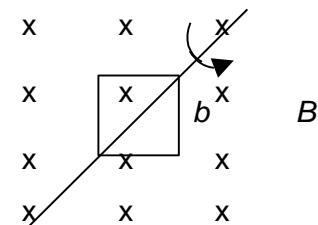

- (a) $b^2 B \omega \sin \omega t$
 (b) $b B \omega \sin^2 \omega t$
 (c) $b B^2 \omega \cos \omega t$
 (d) $b^2 B \omega$

6. A conductor AB lies along the axis of a circular loop of radius R . If the current in the conductor AB varies at the rate of a x ampere/second, then the induced *emf* in the loop is

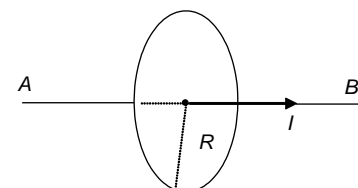

Some important numerical problems on electromagnetic induction

- (a) $\frac{\mu_0 xR}{2}$ (b) $\frac{\mu_0 xR}{4}$
 (c) $\frac{\mu_0 \pi xR}{2}$ (d) zero

7. A current of 10 A flowing in a long straight wire situated near a rectangular loop as shown in figure is switched off and falls to zero in 0.02 second. Find the e.m.f induced in the loop.

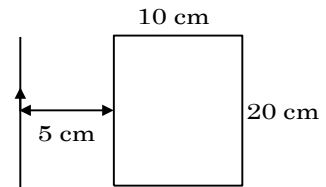

- (a) 22 μ V (b) 11 μ V
 (c) 6 μ V (d) 30 μ V

8. In an inductor of self inductance $L = 2$ mH, current changes with time according to relation $I = t^2 e^{-t}$. At what time emf is zero?

- (a) 1 sec (b) 2 sec (c) 3 sec (d) 4 sec

9. A coil of N turns, made of copper wire of length 4m is placed in a magnetic field that changes with time. The value of N , for which induced emf will be maximum, is

- (a) 1 (b) 2 (c) 3 (d) 4

10. The magnetic field in a region is given by $\vec{B} = B_0 \left(1 + \frac{x}{a}\right) \hat{k}$. A square loop of edge length l is placed with its edges along the X and Y axis. The loop is moved with a constant velocity $\vec{v} = v_0 \hat{i}$. The emf induced in the loop is:

- (a) zero (b) $v_0 B_0 l$ (c) $\frac{v_0 B_0 l^3}{a^2}$ (d) $\frac{v_0 B_0 l^2}{a}$

11. Two conducting rings P and Q of radii r and $3r$ move in opposite directions with velocities $2v$ and v respectively on a conducting surface S . There is a uniform magnetic field of magnitude B perpendicular to the plane of the rings. The potential difference between the highest points of the two ring is

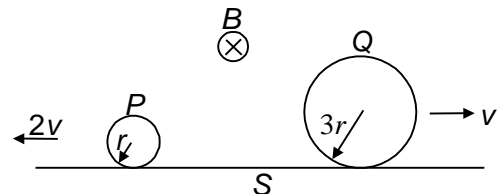

- (a) zero (b) $2Brv$
 (c) $6Brv$ (d) $10Brv$

12. A wire of length one metre is moving at a speed 2 m/sec perpendicular to a magnetic field of induction of 0.5 Tesla. The ends of the wire are formed by a circuit of total resistance 6 ohms. What is the rate at which work is done to keep the wire moving with a constant velocity?

- (a) $\frac{1}{2}$ W (b) $\frac{1}{3}$ W (c) $\frac{1}{6}$ W (d) $\frac{1}{5}$ W

13. In a uniform magnetic field of induction B a wire in the form of a semicircle of radius r rotates about the diameter of the circle with angular frequency ω . The axis of rotation is perpendicular to the field. If the total resistance of the circuit is R , the mean power generated per period of rotation is

- (a) $\frac{B\pi r^2 \omega}{2R}$ (b) $\frac{(B\pi r^2 \omega)^2}{8R}$ (c) $\frac{(B\pi r \omega)^2}{2R}$ (d) $\frac{(B\pi r \omega^2)^2}{8R}$

Some important numerical problems on electromagnetic induction

14. An inductor coil stores energy U when a current i is passed through it and dissipates energy at the rate of P . The time constant of the circuit when this coil is connected across a battery of zero internal resistance is
- (a) $\frac{4U}{P}$ (b) $\frac{U}{P}$ (c) $\frac{2U}{P}$ (d) $\frac{2P}{U}$

15. The magnetic flux through a stationary loop with resistance R varies during interval of time T as $\phi = a t (T-t)$. The heat generated during this time neglecting the inductance of loop will be
- (a) $\frac{a^2 T^3}{3R}$ (b) $\frac{a^2 T^2}{3R}$ (c) $\frac{a^2 T}{3R}$ (d) $\frac{a^3 T^2}{3R}$

16. A non conducting ring having charge q uniformly distributed over its circumference is placed on a rough horizontal surface. A vertical time varying magnetic field $B = 4t^2$ is switched on at time $t = 0$. Mass of the ring is m and radius is R . The ring starts rotating after 2 seconds. The coefficient of friction between the ring and the table is
- (a) $\frac{4qmR}{g}$ (b) $\frac{2qmR}{g}$ (c) $\frac{8qR}{mg}$ (d) $\frac{qR}{2mg}$

17. Two circular coils can be arranged in any of the three situations shown in the figure. Their mutual inductance will be
- (a) maximum in situation (a)
 (b) maximum in situation (b)
 (c) maximum in situation (c)
 (d) the same in all situation

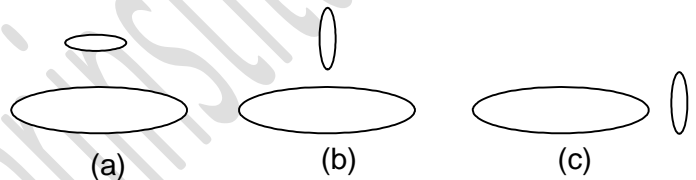

18. A uniform horizontal magnetic field B exists in the region $ABCD$. A rectangular loop of mass m and horizontal side l and resistance R is placed in the magnetic field as shown in the figure. With what velocity should it be pushed down so that it continues to fall without acceleration

- (a) $\frac{mgR}{B^2 l^2}$ (b) $\frac{B^2 l^2}{mgR}$ (c) $\frac{mg}{BIR}$ (d) $\frac{RBI}{mg}$

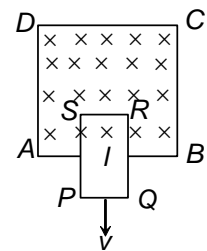

19. Two inductors L_1 and L_2 are connected in parallel and a current $I = I_0 e^{-t} + K_0 e^{-2t}$ flows as shown in figure. The ratio of currents I_1 / I_2 is given by:
- (a) L_1 / L_2 (b) L_2 / L_1
 (c) $(L_1 / L_2) e^{-t}$ (d) $\frac{L_2}{L_1} e^{-t}$

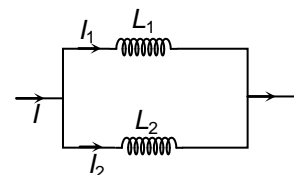

20. A wheel having metals spokes of 1 m long between its axle and rim is rotating in a magnetic field of flux density 5×10^{-5} T normal to the plane of the wheel. An emf of $\frac{22}{7}$ mV is produced between the rim and the axle of the wheel. The rate of rotation of the wheel is

Some important numerical problems on electromagnetic induction

(a) 10 Hz

(b) 20 Hz

(c) 30 Hz

(d) 40 Hz

ONE OR MORE THAN ONE CHOICE CORRECT

1. The conductor $ABCDE$ has the shape shown. It lies in the yz plane, with A and E on the y -axis. When it moves with a velocity v in a magnetic field B , an emf e is induced between A and E .

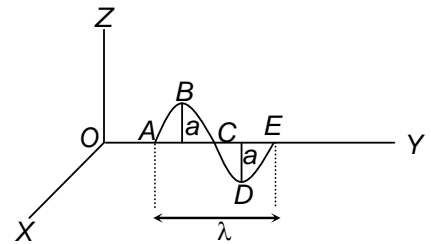

- (a) $e = 0$, if v is in the y -direction and B is in the x -direction
- (b) $e = 2Bav$, if v is in the y -direction and B is in the x -direction
- (c) $e = B\lambda v$, if v is in the z -direction and B is in the x -direction
- (d) $e = B\lambda v$, if v is in the x -direction and B is in the z -direction

2. A conducting disc of radius r spins about its axis with an angular velocity ω . There is a uniform magnetic field of magnitude B perpendicular to the plane of the disc. C is the centre of the ring.

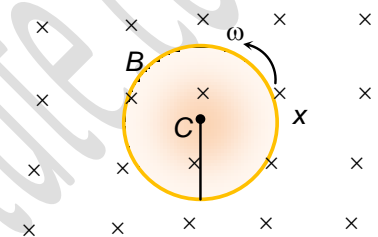

- (a) no emf is induced in the disc
- (b) the potential difference between C and the rim is $\frac{1}{2} Br^2 \omega$
- (c) C is at a higher potential than the rim
- (d) Current flows between C and the rim

3. A conducting rod AC of length $4l$ is rotated about a point O in a uniform magnetic field \vec{B} directed into the paper. $AO = l$ and $OC = 3l$. Then

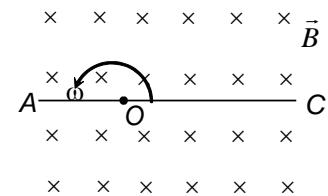

- (a) $V_O - V_A = \frac{B\omega l^2}{2}$
- (b) $V_O - V_C = \frac{9B\omega l^2}{2}$
- (c) $V_A - V_C = 4B\omega l^2$
- (d) $V_C - V_O = \frac{9B\omega l^2}{2}$

4. Two straight conducting rails form a right angle where their ends are joined. A conducting bar in contact with the rails starts at the vertex at $t = 0$ and moves with a constant velocity v along them as shown. A magnetic field B is directed into the page. The induced emf in the circuit at any time t is proportional to

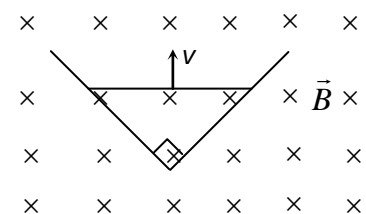

- (a) t^0
- (b) t
- (c) v
- (d) v^2

Some important numerical problems on electromagnetic induction

5. A conducting rod of length l is hinged at point O . It is free to rotate in a vertical plane. There exists a uniform magnetic field \vec{B} in horizontal direction. The rod is released from the position shown. The potential difference between the two ends of the rod at a position when rod makes an angle θ with the horizontal is proportional to
- (a) $l^{3/2}$ (b) l^2
 (c) $\sin \theta$ (d) $(\sin \theta)^{1/2}$

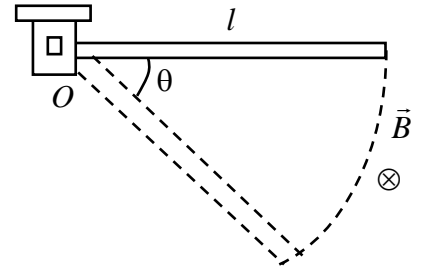

6. A very long wire is carrying current $I = I_0 \sin \omega t$, where I_0 is constant and t is time. A square loop $ABCD$ in the same plane of paper. The direction of induced current in loop is
- (a) A to B , $0 < t < \frac{\pi}{2\omega}$ (b) B to A , $0 < t < \frac{\pi}{2\omega}$
 (c) A to B , $\frac{\pi}{2\omega} < t < \frac{\pi}{\omega}$ (d) B to A , $\frac{\pi}{2\omega} < t < \frac{\pi}{\omega}$

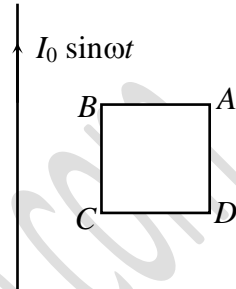

7. Figure shows plane figure made of a conductor located in a magnetic field along the inward normal to the plane of the figure. The magnetic field start diminishing. Then the induced current
- (a) at point P is clockwise
 (b) at point Q is anticlockwise
 (c) at point Q is clockwise
 (d) at point R is zero

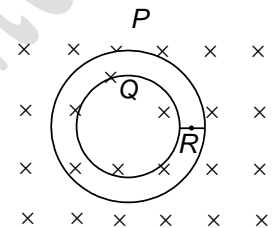

8. Two different coils have self inductances $L_1 = 8$ mH and $L_2 = 2$ mH. The current in one coil is increased at a constant rate. The current in the second coil is also increased at the same constant rate. At a certain instant of time, the power given to the two coils is the same. At this time the current, the induced voltage and the energy stored in the first coil are i_1 , V_1 and U_1 respectively. Corresponding values for the second coil at the same instant are i_2 , V_2 and U_2 respectively. Then (there is no coupling between the two coils)
- (a) $\frac{i_1}{i_2} = \frac{1}{4}$ (b) $\frac{i_1}{i_2} = 4$ (c) $\frac{U_1}{U_2} = \frac{1}{4}$ (d) $\frac{V_2}{V_1} = \frac{1}{4}$

Some important numerical problems on electromagnetic induction

9. A small magnet M is allowed to fall through a fixed horizontal conducting ring R . Let g be the acceleration due to gravity. The acceleration of M will be
- (a) $< g$ when it is above R and moving towards R
 - (b) $> g$ when it is above R and moving towards R
 - (c) $< g$ when it is below R and moving away from R
 - (d) $< g$ when it is below R and moving away from R

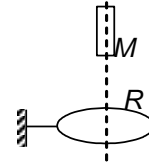

10. If B and E denote induction of magnetic field and energy density at midpoint of a long solenoid, carrying a current i , then which of the following graphs are correct?

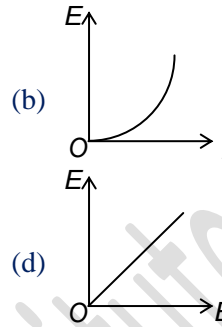
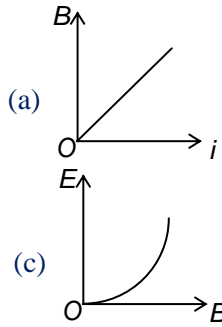

EXERCISE –III

MATCH THE FOLLOWING

Note: Each statement in column – I has one or more than one match in column –II.

1. A conducting loop is held in a magnetic field such that the field is oriented perpendicular to the area of the loop as shown in the figure. At any instant, magnetic flux density over the entire area has the same value but it varies with time as shown in figure (B). Match the column-I with column-II.

Observer

\vec{B} (Positive direction of field)

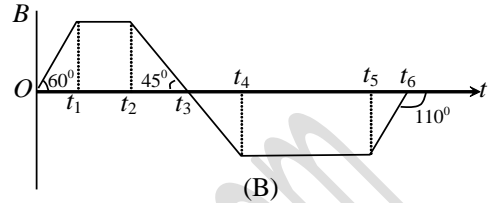
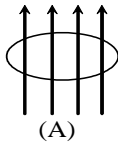

Column I	Column II
I. Induced current in the coil is in the clockwise sense	A. For $t_2 < t < t_3$
II. Induced current in the coil is in the anticlockwise sense	B. For $t_3 < t < t_4$
III. Induced current is zero	C. For $t_5 < t < t_6$
IV. Induced current is maximum	D. For $t_4 < t < t_5$
	E. For $t_2 > t > t_1$

REASONING TYPE

Directions: Read the following questions and choose

- (A) If both the statements are true and statement-2 is the correct explanation of statement-1.
- (B) If both the statements are true but statement-2 is not the correct explanation of statement-1.
- (C) If statement-1 is True and statement-2 is False.
- (D) If statement-1 is False and statement-2 is True.

1. **Statement-1:** The magnetic flux through a closed surface is zero.
Statement-2: Gauss’s law is applicable in the case of electric flux only.
(a) (A) (b) (B) (c) (C) (d) (D)
2. **Statement-1:** A rod oriented along north-south direction when falls under gravity develops a potential difference across its ends.
Statement-2: Emf is not induced across ends of a moving rod if any two of magnetic field,, velocity of rod and length of rod are parallel to each other.
(a) (A) (b) (B) (c) (C) (d) (D)
3. **Statement-1:** When a magnet is made to fall freely through a closed conducting coil, its acceleration is always less than acceleration due to gravity.
Statement-2: Current induced in the coil opposes the motion of the magnet, as per Lenz’s law.
(a) (A) (b) (B) (c) (C) (d) (D)
4. **Statement-1:** When we consider mutual induction between two coils, the emf induced in the two coils is same.
Statement-2: Mutual inductance comes into play when coils are placed close to each other.
(a) (A) (b) (B) (c) (C) (d) (D)
5. **Statement-1:** Resistance of an inductor is always zero.
Statement-2: Inductor is made of some material, and must have some resistance.
(a) (A) (b) (B) (c) (C) (d) (D)

LINKED COMPREHENSION TYPE

The magnetic field at all points within the cylindrical region whose cross-section is indicated in the figure shown; start increasing at a constant rate α T/s. Answer the following questions based on the above statement

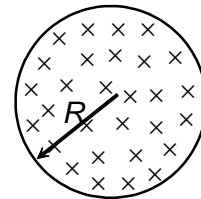

1. The magnitude of the induced electric field at a point at a distance $r(r > R)$ from the geometric centre of the region is

(a) $\frac{r\alpha}{2}$ (b) $\frac{\alpha R^2}{2r}$
(c) $\frac{\alpha r^2}{2R}$ (d) $r\alpha$

2. The magnitude of the electric force on an electron (charge $=e$) placed at a distance $r(r > R)$ from the geometric centre of the region is

(a) $\frac{e r \alpha}{2}$ (b) $\frac{2 \alpha r^2}{2 R}$
(c) $\frac{e \alpha R^2}{2 r}$ (d) $e r \alpha$

3. The variation of the magnitude of the induced electric field (E) with distance r from the geometric centre of the region, is best represented by the graph

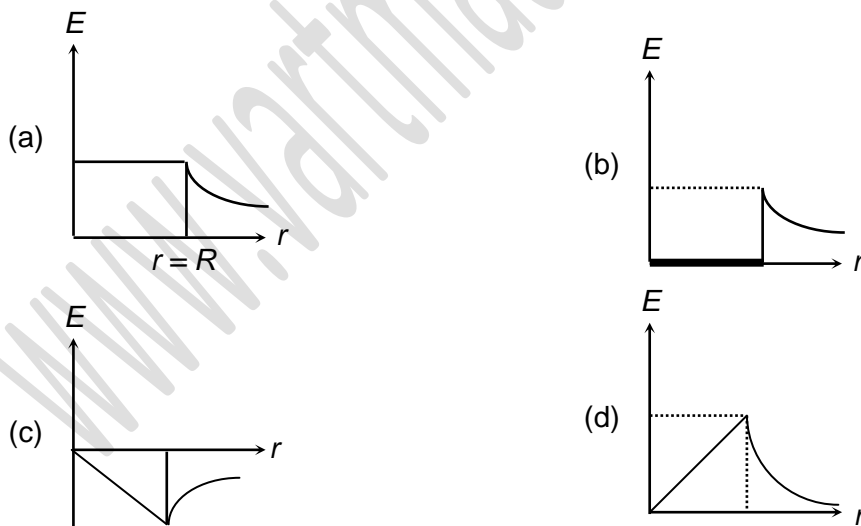

EXERCISE – IV

SUBJECTIVE PROBLEMS

Some important numerical problems on electromagnetic induction

1. A non conducting ring of mass $m = 100 \text{ g}$ and radius $R = 10 \text{ cm}$ has a charge $Q=1\text{C}$ uniformly distributed over its circumference. The ring is placed on a rough horizontal surface such that plane of the ring is parallel to the surface. A vertical magnetic field $B = B_0 t^2$ tesla where $B_0 = 2\text{T/s}^{-1}$ is switched on. After $t = 2$ seconds from switching on the magnetic field the ring is just about to rotate about vertical axis through its centre. The friction coefficient μ between the ring and the surface is found to be $(x \times 10^{-1})$. Find the value of x .

2. A stiff wire ab bent into a semicircle of radius $R = 50\text{cm}$ is rotated with a frequency $f = 50\text{Hz}$ in a uniform field of induction $B = 2\text{T}$, as shown in the Figure. What is the amplitude of the induced current (in ampere) when the internal resistance of the meter M is $R_M = 125 \Omega$ and the remainder of the circuit has negligible resistance? ($\pi^2 \approx 10$)

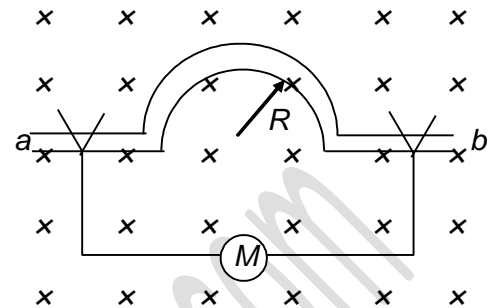

3. A wire in the shape of a parabola $y = 2x^2$ is in a uniform magnetic field $B=4\text{T}$ perpendicular to the plane xy . A jumper starts with a constant acceleration $a = 1\text{m/s}^2$ from the apex of the parabola. Find the emf induced (in volt) in the formed loop when $y = 1\text{m}$.

4. A square loop of side $a = 10 \text{ cm}$ and a straight infinite conductor are placed in the same plane with two sides of the square parallel to the conductor carrying current $I = 10 \text{ A}$. The inductance and resistance are equal to $L = 5 \text{ mH}$ and $R = 100\Omega$ respectively. The frame is turned through 180° about axes OO' . Find the electric charge (in pC) that flows in the square loop during a long time interval.

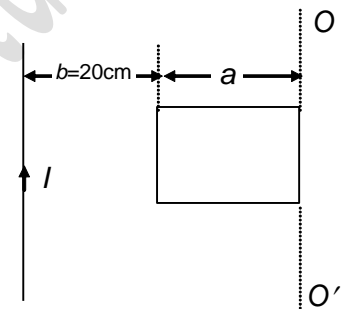

5. A square loop of side $a = 10 \text{ cm}$ with its sides parallel to the x and y -axes is moved with a constant velocity $v = 8 \text{ cm/sec}$ in the positive x -direction, in an environment in which there is a magnetic field along the z -direction. It has a gradient $\frac{\partial B}{\partial x} = 10^{-3} \text{ tesla/m}$ along x -axis and the time decreasing rate $\frac{dB}{dt} = -10^{-3} \text{ tesla/sec}$. The resistance of the square loop is 5Ω . The current in the loop is found to be $(x \times 10^{-8}) \text{ A}$. Find the value of x ?

6. A square loop of wire of side $l = 1\text{cm}$ is placed inside a large square loop of wire of side $L = 1\text{m}$. The loops are coplanar and their centres coincide. Find the mutual inductance (in pH) of the system.

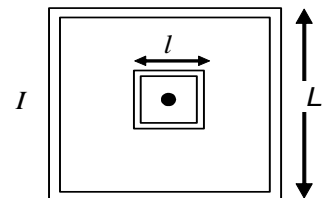

Some important numerical problems on electromagnetic induction

7. A pair of parallel horizontal conducting rails of negligible resistance shorted at one end is fixed on a table. The distance between the rails is $l = 1\text{m}$. A conducting massless rod of resistance $R = 10\Omega$ can slide on the rails frictionlessly. The rod is tied to a massless string, which passes over a pulley fixed to the edge of the table. A mass $m = 1\text{kg}$ tied to the other end of the string, hangs vertically. A constant magnetic field $B = 10\text{T}$ exists perpendicular to the table. If the system is released from rest, calculate the acceleration of the mass at the instant when the velocity of the rod is half of the terminal velocity. ($g = 10\text{m/s}^2$)

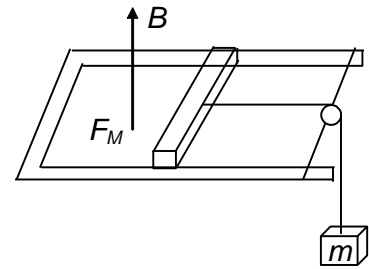

8. Two parallel vertical metallic rails AB and CD are separated by 1m . They are connected at the two ends by resistances R_1 and R_2 as shown in Figure. A horizontal metallic bar L of mass $m = 0.2\text{kg}$ slides without friction vertically down the rails under the action of gravity. There is a uniform horizontal magnetic field of $B = 0.6\text{T}$ perpendicular to the plane of the rails. It is observed that when the terminal velocity is attained the powers dissipated in R_1 and R_2 are 0.76W and 1.2W respectively. Find the terminal velocity of the bar L .

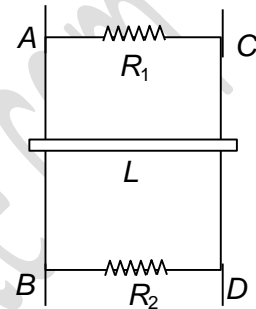

9. A very long conductor and an isosceles triangular conductor lie in a plane and separated from each other, as shown in the figure. $a = 10\text{cm}$, $b = 2\text{cm}$, $h = 10\text{cm}$. Find the co-efficient of mutual induction (in pH) ($\ln 2 = 0.693$)

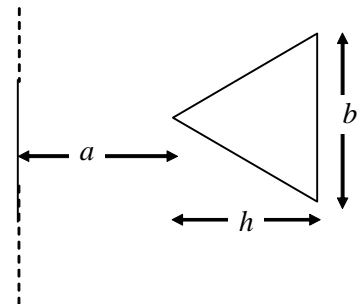

10. A square frame with side $a = 2\text{cm}$ and a long straight wire carrying a current $I = 2\text{A}$ are located in the same plane, as shown in Figure. The frame moves to the right with a constant velocity $v = 20\text{m/s}$. Find the emf induced (in nV) when $y = 2\text{cm}$.

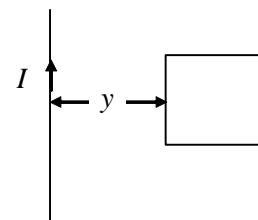

ANSWERS

EXERCISE – I

NEET-SINGLE CHOICE CORRECT

1. (b)	2. (b)	3. (d)	4. (c)	5. (d)
6. (a)	7. (b)	8. (b)	9. (a)	10. (c)
11. (a)	12. (a)	13. (b)	14. (b)	15. (d)
16. (b)	17. (a)	18. (a)	19. (c)	20. (c)
21. (a)	22. (c)	23. (d)	24. (a)	25. (b)

EXERCISE – II

IIT-JEE-SINGLE CHOICE CORRECT

1. (c)	2. (c)	3. (b)	4. (a)	5. (a)
6. (d)	7. (a)	8. (b)	9. (a)	10. (d)
11. (d)	12. (c)	13. (b)	14. (c)	15. (a)
16. (c)	17. (a)	18. (a)	19. (b)	20. (b)

ONE OR MORE THAN ONE CHOICE CORRECT

1. (a,c,d)	2. (b,c)	3. (a,c)	4. (b,d)	5. (a,d)
6. (a,d)	7. (a,c,d)	8. (a,d)	9. (a,c)	10. (a,b,c)

EXERCISE – III

MATCH THE FOLLOWING

1. I – C; II – A, B; III – D, E; IV – C

REASONING TYPE

1. (c)	2. (d)	3. (a)	4. (d)	5. (d)
--------	--------	--------	--------	--------

LINKED COMPREHENSION TYPE

1. (b)	2. (c)	3. (d)
--------	--------	--------

EXERCISE – IV

SUBJECTIVE PROBLEMS

- $\mu = \frac{qrB_0 t}{mg}$; 4
- $amp = \frac{BA2\pi f}{R_m}$; 2
- $e = 2BY\sqrt{a}$; 8
- $q = \frac{\mu_0}{2\pi R} \frac{Ia}{b} \ln \frac{b+2a}{b}$; 1386
- $i = -\frac{a^2}{R} \left[\frac{\partial B}{\partial x} V + \frac{dB}{dt} \right]$; 184
- $M = \frac{\mu_0}{\pi} \frac{2\sqrt{2}I^2}{L}$; 113
- $a = \frac{g}{2}$; 5
- $V_T = \frac{mg}{B^2 L^2} \left[\frac{R_1 R_2}{R_1 + R_2} \right]$; 1
- $M = \frac{\mu_0 b}{2\pi h} \left[h - a \ln \left(\frac{a+b}{a} \right) \right]$; 1228
- $e = \frac{\mu_0}{4\pi} \frac{2ia^2 V}{Y(Y+a)}$ Volt; 4

IMPORTANT PRACTICE QUESTION SERIES FOR IIT-JEE EXAM - 1

- Q.1** A flux of 1m Wb passes through a strip having an area $A = 0.02 \text{ m}^2$. The plane of the strip is at an angle of 60° to the direction of a uniform field B. The value of B is-

Some important numerical problems on electromagnetic induction

- (1) 0.1 T
(2) 0.058 T
(3) 4.0 mT
(4) none of the above.
- Q.2** A small loop of area of cross section 10^{-4} m^2 is lying concentrically and coplanar inside a bigger loop of radius 0.628m. A current of 10A is passed in the bigger loop. The smaller loop is rotated about its diameter with an angular velocity ω . The magnetic flux linked with the smaller loop will be-
- (1) $10^{-7} \sin \omega t$ (2) $10^{-7} \cos \omega t$
(3) $10^{-9} \sin \omega t$ (4) $10^{-9} \cos \omega t$
- Q.3** A coil of N turns and area A is rotated at the rate of n rotations per second in a magnetic field of intensity B, the magnitude of the maximum magnetic flux will be-
- (1) NAB (2) nAB
(3) NnAB (4) $2\pi nNAB$
- Q.4** The number of turns in a long solenoid is 500. The area of cross-section of solenoid is $2 \times 10^{-3} \text{ m}^2$. If the value of magnetic induction, on passing a current of 2 amp, through it is 5×10^{-3} Tesla, the magnitude of magnetic flux connected with it in Weber will be-
- (1) 5×10^{-3} (2) 10^{-2}
(3) 10^{-5} (4) 2.5
- Q.5** The instantaneous flux associated with a closed circuit of 10Ω resistance is indicated by the following reaction $\phi = 6t^2 - 5t + 1$, then the value in amperes of the induced current at $t = 0.25$ sec will be-
- (1) 1.2 (2) 0.8
(3) 6 (4) 0.2
- Q.6** A cylindrical bar magnetic is lying along the axis of a circular coil. If the magnet is rotated about the axis of the coil then-
- (1) e.m.f. will be induced in the coil
(2) Only induced current will be generated in the coil
(3) No current will be induced in the coil
(4) Both e.m.f. and current will be induced in the coil
- Q.7** When a coil of area 2 cm^2 and having 30 turns, whose plane is normal to the magnetic field, is drawn out of the magnetic field, a charge of 1.5×10^{-4} coulomb flows in the circuit. If its resistance is 40 ohm, then the magnetic flux density in Tesla will be-
- (1) 10 (2) 0.1 (3) 1 (4) 0.01
- Q.8** When a magnet is being moved towards a coil, the induced emf does not depend upon-
- (1) the number of turns of the coil
(2) the motion of the magnet
(3) the magnetic moment of the magnet
(4) the resistance of the coil
- Q.9** A wire carrying current I, lie on the axis of a conducting ring. The direction of the induced current in the ring, when I is decreasing at a steady rate is-

Some important numerical problems on electromagnetic induction

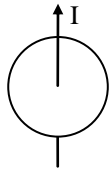

- (1) clockwise
- (2) anticlockwise
- (3) alternatively clockwise and anticlockwise
- (4) no induced current flow in the ring

Q.10 A magnet is brought towards a fixed coil rapidly. Due to this induced emf, current and charge are E , I and Q respectively. If the speed of the magnet is doubled, then wrong statement is-

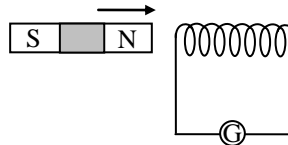

- (1) E increases
- (2) I increases
- (3) Q remains unchanged
- (4) Q increases

Q.11 A field of $5 \times 10^4/\pi$ ampere-turns/metre acts at right angles to a coil of 50 turns of area 10^{-2} m^2 . The coil is removed from the field in 0.1 second. Then the induced emf in the coil is-

- (1) 0.1 V
- (2) 80 KV
- (3) 7.96 V
- (4) none of the above

Q.12 A coil having n turns and area A is initially placed with its plane normal to the magnetic field B . It is then rotated through 180° in 0.2 sec. The emf induced at the ends of the coils is-

- (1) 0.1 nAB
- (2) nAB
- (3) 5 nAB
- (4) 10 nAB

Q.13 A conducting circular loop is placed in a uniform magnetic field $B = 40 \text{ mT}$ with its plane perpendicular to the field. If the radius of the loop starts shrinking at a constant rate of 2 mm/s , then the induced emf in the loop at an instant when its radius is 1.0 cm is-

- (1) $0.1 \pi \mu \text{ V}$
- (2) $0.2 \pi \mu \text{ V}$
- (3) $1.0 \pi \mu \text{ V}$
- (4) $1.6 \pi \mu \text{ V}$

Q.14 Two plane circular coils P and Q have radii r_1 and r_2 , respectively, ($r_1 < r_2$) and are coaxial as shown in fig. The number of turns in P and Q are respectively N_1 and N_2 . If current in coil Q is varied steadily at a rate x ampere/sec then the induced emf in the coil P will be approximately-

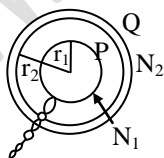

- (1) $\mu_0 N_1 N_2 \pi r_1^2$
- (2) $\mu_0 N_1 N_2 \pi r_1^2 x$
- (3) $\mu_0 N_1 N_2 \pi r_1^2 x / 2r_2$
- (4) 0

Q.15 The rate of change of magnetic flux density through a circular coil of area 10^{-2} m^2 and number of turns 100 is $10^3 \text{ Wb/m}^2/\text{s}$. The value of induced e.m.f. will be -

- (1) 10^{-2} V
- (2) 10^{-3} V
- (3) 10V
- (4) 10^3 V

Some important numerical problems on electromagnetic induction

- Q.16** A long solenoid contains 1000 turns/cm and an alternating current of peak value 1A is flowing in it. A search coil of area of cross-section $1 \times 10^{-4} \text{ m}^2$ and having 50 turns is placed inside the solenoid with its plane perpendicular to the axis of the solenoid. A peak voltage of $2\pi^2 \times 10^{-2} \text{ V}$ is produced in the search coil. The frequency of current in the solenoid will be -
(1) 50 Hz (2) 100 Hz
(3) 500 Hz (4) 1000 Hz
- Q.17** A coil of cross-sectional area $5 \times 10^{-4} \text{ m}^2$ and having number of turns 1000 is placed perpendicular to a magnetic field of 10^{-2} T . The coil is connected to a galvanometer of resistance 500Ω . The induced charge generated in the coil on rotating it through an angle of π radian will be -
(1) $10 \mu\text{C}$ (2) $20 \mu\text{C}$ (3) $50 \mu\text{C}$ (4) $100 \mu\text{C}$
- Q.18** Lenz's law is consistent with law of conservation of -
(1) current (2) emf
(3) energy (4) all of the above
- Q.19** The north pole of a magnet is brought near a coil. The induced current in the coil as seen by an observer on the side of magnet will be-
(1) in the clockwise direction
(2) in the anticlockwise direction
(3) initially in the clockwise and then anticlockwise direction
(4) initially in the anticlockwise and then clockwise direction.

- Q.20** A magnetic field is directed normally downwards through a metallic frame as shown in the figure. On increasing the magnetic field-

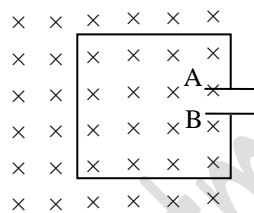

- (1) plate B will be positively charged
(2) plate A will be positively charged
(3) none of the plates will be positively charged
(4) all of the above
- Q.21** Two coils P and Q are lying a little distance apart coaxially. If a current I is suddenly set up in the coil P then the direction of current induced in coil Q will be-

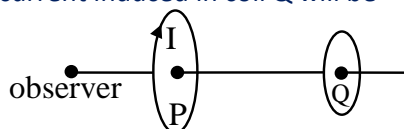

- (1) clockwise (2) towards north
(3) towards south (4) anticlockwise
- Q.22** A system S consists of two coils A and B. The coil A carries a steady current I while the coil B is suspended near by as shown in fig. Now if the system is heated so as to raise the temperature of two coils steadily then-

Some important numerical problems on electromagnetic induction

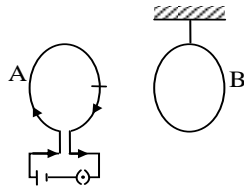

- (1) the two coils show attraction
- (2) the two coils show repulsion
- (3) there is no change in the position of the two coils
- (4) induced currents are not possible in coil B.

Q.23 Consider the situation shown in fig. If the current I in the long straight wire XY is increased at a steady rate then the induced emf's in loops A and B will be-

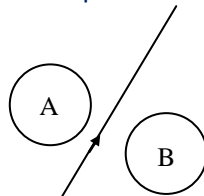

- (1) clockwise in A, anticlockwise in B
- (2) anticlockwise in A, clockwise in B
- (3) clockwise in both A and B
- (4) anticlockwise in both A and B

Q.24 A conducting ring is placed around the core of an electromagnet as shown in fig. When key K is pressed, the ring-

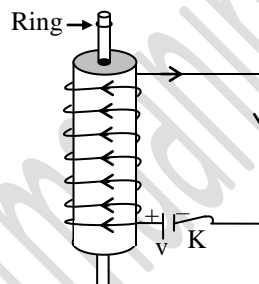

- (1) remains stationary
- (2) is attracted towards the electromagnet
- (3) jumps out of the core
- (4) none of the above

Q.25 A copper ring having a cut such as not to form a complete loop is held horizontally and a bar magnet is dropped through the ring with its length along the axis of the ring. Then acceleration of the falling magnet is- (neglect air friction)-

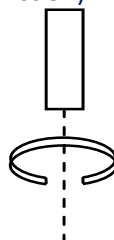

- (1) g
- (2) less than g
- (3) more than g
- (4) 0

Q.26 The north pole of a magnet is brought away from a coil, then the direction of induced current will be-

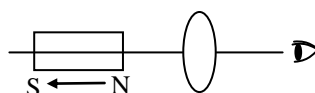

- (1) in the clockwise direction

Some important numerical problems on electromagnetic induction

- (2) in the anticlockwise direction
- (3) initially in the clockwise and then anticlockwise direction
- (4) initially in the anticlockwise and then clockwise direction.

Q.27 A metal sheet is placed in a variable magnetic field which is increasing from zero to maximum. Induced current flows in the directions as shown in figure. The direction of magnetic field will be-

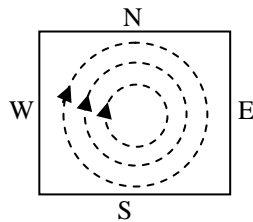

- (1) normal to the paper, inwards
- (2) normal to the paper, outwards.
- (3) from east to west
- (4) from north to south

Q.28 A square loop PQRS is carried away from a current carrying long straight conducting wire CD. The direction of induced current in the loop will be-

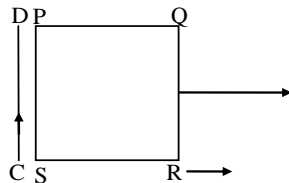

- (1) anticlockwise
- (2) clockwise
- (3) sometimes clockwise some times anticlockwise
- (4) current will not be induced

Q.29 A thin sheet of conductor, when allowed to oscillate in a magnetic field normal to the sheet, then the motion is-

- (1) damped due to air friction
- (2) damped due to eddy currents
- (3) accelerated due to eddy currents
- (4) not effected by induced currents

Q.30 P and Q are two circular thin coils of same radius and subjected to the same rate of change of flux. If coil P is made up of copper and Q is made up of iron, then the wrong statement is-

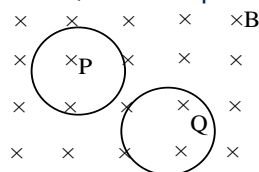

- (1) emf induced in the two coils is the same
- (2) the induced current in P is more than that in Q
- (3) the induced current in P and Q are in the same direction
- (4) the induced currents are the same in both the coils.

Q.31 A wire of length 4 m placed normal to the magnetic field of $(2\hat{i} + 4\hat{j})$ Tesla is moving with a velocity $(4\hat{i} + 6\hat{j} + 8\hat{k})$ m/s. The emf induced across the ends of the wire will be-

- (1) 4 V
- (2) 8 V
- (3) 16 V
- (4) 32 V

Q.32 A rectangular loop of resistance R, and sides l and x, is pulled out of a uniform magnetic field B with a steady velocity v. The necessary force F required for maintaining uniform velocity of withdrawal is-

Some important numerical problems on electromagnetic induction

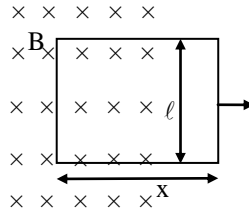

- (1) $\frac{Bl^2v}{R}$ (2) $\frac{B^2l^2v}{R}$
 (3) $\frac{B^2l^2v^2}{R}$ (4) 0

Q.33 A small conducting rod of length ℓ , moves with a uniform velocity v in a uniform magnetic field B as shown in fig-

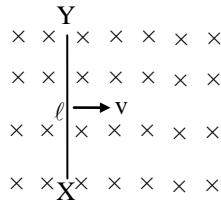

- (1) Then the end X of the rod becomes positively charged
 (2) the end Y of the rod becomes positively charged
 (3) the entire rod is unevenly charged
 (4) the rod becomes hot due to joule heating.

Q.34 A conductor ABCD moves along its bisector with a velocity of 1 m/s through a perpendicular magnetic field of 1 Wb/m², as shown in fig. If all the four sides are of 1m length each, then the induced emf between points A and D is-

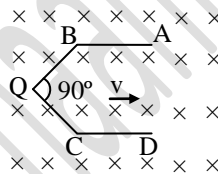

- (1) 0
 (2) 1.41 volt
 (3) 0.71 volt
 (4) none of the above

Q.35 A circular coil of radius r is placed in a uniform magnetic field B . The magnetic field is normal to the plane of the coil, as shown in fig. Now if the coil is rotated at an angular speed of ω , about its own axis, then the induced emf in the coil is-

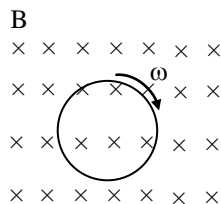

- (1) $\frac{BA\omega}{2\pi}$ (2) $B(2\pi r)\omega$

Some important numerical problems on electromagnetic induction

- (3) 0 (4) None of the above

Q.36 An electric potential difference will be induced between the ends of the conductor shows in fig, when conductor moves in the direction-

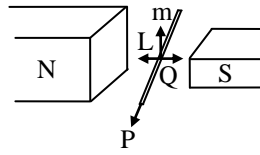

- (1) P (2) Q (3) L (4) M

Q.37 A square conducting loop of side L and resistance R is moving with a uniform velocity at right angles to one of the sides in its own plane. On applying a uniform magnetic field at right angles to its plane as shown in the figure the induced current in the loop will be -

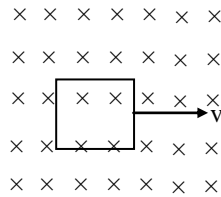

- (1) Zero
 (2) $\frac{BLv}{R}$ in anticlockwise direction
 (3) $\frac{BLv}{R}$ in clockwise direction
 (4) $\frac{2BLv}{R}$ in clockwise direction

Q.38 A circular copper disc of radius 25 cm is rotating about its own axis with a constant angular velocity of 130 rad/s. If a magnetic field of 5×10^{-3} Tesla is applied at right angles to the disc, then the induced potential difference between the centre and the rim of the disc will approximately be -

- (1) 20×10^{-3} V (2) 20×10^{-6} V
 (3) 20×10^{-9} (4) Zero

Q.39 A 1.2m wide railway track is parallel to magnetic meridian. The vertical component of earth's magnetic field is 0.5 oersted. When a train runs on the rails at a speed of 60Km/hr, then the induced potential difference between the ends of its axle will be-

- (1) 10^{-4} V (2) 2×10^{-4} V
 (3) 10^{-3} V (4) Zero

Q.40 A conducting wheel in which there are four rods of length ℓ is rotating with angular velocity ω in a uniform magnetic field B. The induced potential difference between its centre and rim will be -

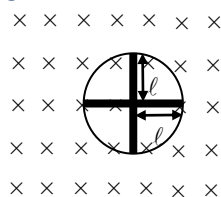

- (1) 0 (2) $B\ell^2\omega$ (3) $B^2\ell\omega$ (4) $\frac{B\ell^2\omega}{2}$

Q.41 A small straight conductor PQ is lying at right angles to an infinite current carrying conductor XY. If the conductor PQ is displaced on metallic rails parallel to the conductor XY then the direction of induced e.m.f. in the PQ will be-

Some important numerical problems on electromagnetic induction

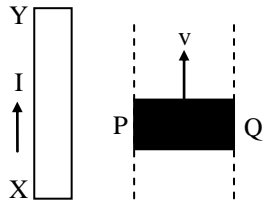

- (1) From Q to P
- (2) From P to Q
- (3) Vertically downwards
- (4) Vertically upwards

Q.42 A straight conductor carrying current i and a loop closed by a sliding connector of resistance R lie in the same plane. The connector slides towards right with a uniform velocity v . The induced current generated in the loop in terms of distance r of the connector from the straight conductor will be -

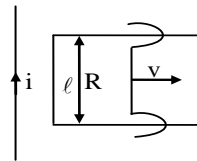

- (1) $\frac{\mu_0 i \ell v}{2\pi r}$
- (2) $\frac{\mu_0 i \ell}{2\pi r}$
- (3) $\frac{\mu_0 i \ell v}{2\pi r R}$
- (4) None of these

Q.43 The spokes of a wheel are made of metal and their lengths are of one metre. On rotating the wheel about its own axis in a uniform magnetic field of 5×10^{-5} Tesla normal to the plane of wheel, a potential difference of 3.14 mV is generated between the rim and the axis. The rotational velocity of the wheel is-

- (1) 63 rev./s
- (2) 50 rev./s
- (3) 31.4 rev./s
- (4) 20 rev./s

Q.44 A metal rod completes a circuit as shown in the figure. The circuit is normal to a magnetic field $B = 0.15$ T. If the resistance of the circuit is 3 ohm then the force required to move the rod with a constant velocity of 2 m/s will be-

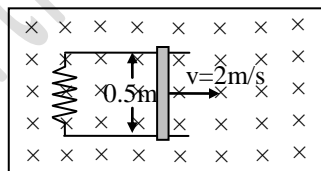

- (1) 3.75×10^{-3} N
- (2) 3.75×10^{-2} N
- (3) 3.75×10^2 N
- (4) 3.75×10^{-4} N

Q.45 The significance of self inductance L is the same as of that of in the linear motion-

- (1) mass
- (2) velocity
- (3) acceleration
- (4) displacement

Q.46 On making a coil of copper wire of length ℓ and coil radius r , the value of self inductance is obtained as L . If the coil of same wire, but of coil radius $r/2$, is made, the value of self inductance will be-

- (1) $2L$
- (2) L
- (3) $4L$
- (4) $L/2$

Q.47 Out of the two coils placed near each other, when a current of 2 amp is passed in one, a flux of 6×10^{-5} Weber passes through the other. If the number of turns in the secondary coils is 20, the value of coefficient of mutual induction in the coils will be-

- (1) 6H
- (2) 6 mH
- (3) 0.6H
- (4) 0.6 mH

Q.48 The coefficient of mutual induction between two coils is 4H. If the current in the primary reduces from 5A to zero in 10^{-3} second then the induced e.m.f. in the secondary coil will be-

Some important numerical problems on electromagnetic induction

- (1) 10^4 V (2) 25×10^3 V
(3) 2×10^4 V (4) 15×10^3 V
- Q.49** The coefficient of mutual induction between two closely lying coils does not depend upon-
- (1) their mutual orientation
 - (2) the permeability of their core material
 - (3) their structure
 - (4) the current flowing in them
- Q.50** The number of turns in a coil of wire of fixed radius is 600 and its self inductance is 108 mH. The self inductance of a coil of 500 turns will be-
- (1) 74 mH (2) 75 mH
 - (3) 76 mH (4) 77 mH
- Q.51** The value of the self inductance of a coil is 5 H. If the current in the coil changes steadily from 1A to 2A in 0.5 seconds, then the magnitude of induced emf is-
- (1) 1V (2) 10 V (3) 100 V (4) 0.1 V
- Q.52** An inductance stores energy in-
- (1) electric field (2) magnetic field
 - (3) resistance of coils (4) all of the above
- Q.53** A thin copper wire of length 100 metres is wound as a solenoid of length ℓ and radius r . Its self inductance is found to be L . Now if the same length of wire is wound as a solenoid of length ℓ but of radius $r/2$, then its self inductance will be-
- (1) $4L$ (2) $2L$ (3) L (4) $L/2$
- Q.54** The coefficient of coupling between two coil is maximum when the two coils are-
- (1) placed at right angles
 - (2) placed parallel at close distance
 - (3) wound around a common ferromagnetic core and insulated from it
 - (4) placed at an angle of 45° with each other
- Q.55** Two coils of self inductances L_1 and L_2 are tightly wrapped one over the other. The maximum mutual inductance of the combination will be-
- (1) $L_1 + L_2$ (2) $L_1 L_2$
 - (3) $\sqrt{L_1 L_2}$ (4) $\frac{L_1 L_2}{L_1 + L_2}$
- Q.56** The coefficient of mutual inductance of the two coils is 5 H. The current through the primary coil is reduced to zero value from 3A in 1 milli second. The induced emf in the secondary coils is-
- (1) 0 (2) 1.67 KV
 - (3) 15 KV (4) 600 V
- Q.57** The value of coefficient of mutual induction in two coils can be increased by-
- (1) placing the coils mutually perpendicular.
 - (2) keeping the coils near to each other.
 - (3) keeping the coils considerably apart.
 - (4) winding the core on the common iron magnetic material and insulating them.
- Q.58** The current is reduced from 3 amp to zero in 0.001 sec. in the primary coil. It induces an emf of 15000 volts in the secondary. The value of coefficient of mutual inductance in Henry will be-
- (1) 5 (2) 0.5 (3) 4.5 (4) 50
- Q.59** A solenoid having a core of cross-section 4 cm^2 , half air and half iron (relative permeability = 500), is 22 cm long. If the number of turns on it is 10^3 its self inductance is-
- (1) 570 H (2) 57 H

Some important numerical problems on electromagnetic induction

- (3) 5.7 H (4) 0.57 H

- Q.60** The coefficients of self induction of two inductance coils are 0.01H and 0.03H respectively. When they are connected in series so as to support each other, then the resultant self inductance becomes 0.06 Henry. The value of coefficient of mutual induction will be-
- (1) 0.02 H (2) 0.05 H
(3) 0.01 H (4) zero
- Q.61** Two identical solenoid coils, each of self inductance L are connected in series. Their turns are in the same sense, and the distance between them is such that the coefficient of coupling is half. Then the equivalent inductance of the combination is-
- (1) L (2) 2L
(3) 3L (4) L/2
- Q.62** If two coils of negligible mutual induction and having coefficient of inductances L_1 and L_2 ($L_1 > L_2$) are arranged in parallel, the value of the equivalent self-induction will be-
- (1) $L_1 L_2 / (L_1 - L_2)$ (2) $L_1 L_2 / (L_1 + L_2)$
(3) $(L_1 + L_2) / L_1 L_2$ (4) $(L_1 - L_2) / L_1 L_2$
- Q.63** The self inductance and resistance of a coil are 5H and 20 Ω respectively. On applying an e.m.f. of 100 V on it, the magnetic potential energy stored in the coil will be-
- (1) 62.5 Joule (2) 62.5 erg
(3) 62.5×10^{-3} Joule (4) zero
- Q.64** The energy stored in an inductance is 1 joule when a current of 0.1 A is established in it. The self-inductance of the coil is-
- (1) 25 H (2) 50 H
(3) 200 H (4) 2.6 H
- Q.65** The growth of current in an L - R circuit in time $t = L / R$ is equal to about-
- (1) 37% of maximum (2) 63% of maximum
(3) 57% of maximum (4) 67% of maximum
- Q.66** The current in an L-R circuit in a time $t = 2L / R$ reduces to-
- (1) 36.5% of maximum
(2) 13.5% of maximum
(3) 0.50% of maximum
(4) 63.2% of maximum
- Q.67** A coil of 10 H inductance has a 5 Ω resistance and is connected to a 5 volt battery in series. The current in ampere in the circuit 2 seconds after the circuit is switched on is-
- (1) 1 amp
(2) $(1 - 1/e)$ amp
(3) $(1 - e)$ amp
(4) $1/e$ amp.
- Q.68** A coil of resistance R and inductance L is connected to a battery of E volt e.m.f. This final current in the coil is-
- (1) E/R (2) E/L
(3) $\sqrt{[E/(R^2 + L^2)]}$ (4) $\sqrt{[EL/(R^2 + L^2)]}$
- Q.69** Calculate the ratio of power dissipated by the bulb at $t = 1$ sec and $t = 2$ sec after closing the switch-

Some important numerical problems on electromagnetic induction

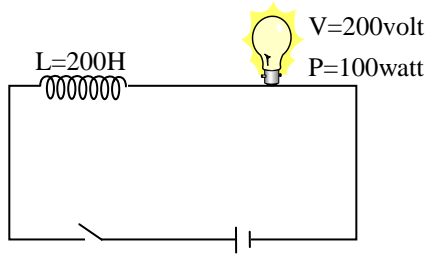

- (1) $\frac{e^2}{e^4 - 1}$ (2) $\frac{e^2}{(e^2 + 1)}$
 (3) $\frac{e^2 - 1}{e^4 + 1}$ (4) None of these

Q.70 Calculate the ratio of current flowing through the battery at $t = 0$ and $t = \infty$. ($t = 0$ is the time of closing of switch)-

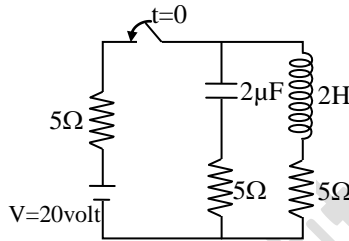

- (1) 1 (2) 2 (3) $\frac{1}{2}$ (4) 0

Q.71 Plot the variation of emf across the inductor with respect time-

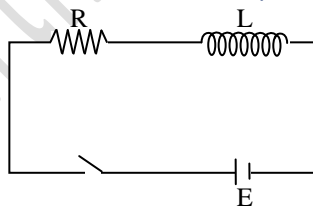

- (1) (2)
 (3) (4)

Q.72 To transmit electrical energy from a generator to distant consumers-

- (1) high voltage and low current are transmitted
 (2) high voltage and high current are transmitted
 (3) low voltage and low current are transmitted
 (4) low voltage and high current are transmitted

Some important numerical problems on electromagnetic induction

- Q.73** A transformer transforms 220 volts to 11 volts. If the current strength in the primary coil is 5 amp. and that in the secondary, 90 amp, what is the efficiency of the transformer-
- (1) 90 % (2) 100 %
(3) 211 % (4) 150 %
- Q.74** A step up transformer operates on a 230 volt line and supplies a load of 2 amp. The ratio of primary and secondary windings is 1 : 25. Determine the primary current-
- (1) 12.5 amp (2) 50 amp
(3) 8.8 amp (4) 25 amp
- Q.75** A transformer is used to light 140 watt 24 volt lamp from 240 volt AC mains, the current in the main cable is 0.7 amp. The efficiency of the transformer is-
- (1) 63.8% (2) 84% (3) 83.3% (4) 48%
- Q.76** In a step-up transformer, in comparison with the secondary the primary coil has-
- (1) less voltage and high current
(2) high voltage and less current
(3) less voltage and less current
(4) high voltage and high current
- Q.77** In the secondary coil of step-up transformer, the number of turns are-
- (1) more and the copper wire is thicker
(2) more and the copper wire is thinner
(3) less and the copper wire is thicker
(4) less and the copper wire is thinner
- Q.78** A dynamo-
- (1) creates electrical energy
(2) converts mechanical energy into electrical energy
(3) converts electrical energy into mechanical energy
(4) creates mechanical energy

IMPORTANT PRACTICE QUESTION SERIES FOR IIT-JEE EXAM - 2

- Q.1** The coefficient of mutual inductance of two circuits A and B is 3 mH and their respective resistances are 10 ohm and 4 ohm. How much current should change in 0.02 second in the circuit A. So that the induced current in B should be 0.006 ampere-
- (1) 0.24 amp (2) 1.6 amp
(3) 0.18 amp (4) 0.16 amp
- Q.2** The coefficient of self inductance is 5 mH. If the emf of the cell in the circuit is 1.1 volt and at any instant the rate of increase of current is 6 ampere/second, then at that instant, the resultant e.m.f. in the circuit will be-
- (1) 1.13 V (2) 0.13 V
(3) 1.07 V (4) 1.4 V
- Q.3** The phase difference between the flux linkage and the induced e.m.f. in a rotating coil in a uniform magnetic field is-
- (1) π (2) $\pi/2$
(3) $\pi/4$ (4) $\pi/6$
- Q.4** A dynamo is sometimes said to generate electricity. It actually acts as a source of-
- (1) charge
(2) magnetism
(3) e.m.f.
(4) energy

Some important numerical problems on electromagnetic induction

- Q.5** In a step-down transformer the number of turns in-
- (1) primary are less
 - (2) primary are more
 - (3) primary and secondary are equal
 - (4) primary are infinite
- Q.6** An inductor coil stores 32 J of magnetic field energy and dissipates energy as heat at the rate of 320 W, when a current of 4 A is passed through it. The time constant of the circuit when this coil is joined across an ideal battery will be-
- (1) 0.2 s
 - (2) 0.3 s
 - (3) 0.4 s
 - (4) 0.5 s
- Q.7** A solenoid of inductance 50 mH and resistance 10 Ω is connected to a battery of 6 V. The time elapsed before the current acquires half of its steady-state value will be-
- (1) 3.01 s
 - (2) 3.02 s
 - (3) 3.03 s
 - (4) 3.5 ms
- Q.8** An inductor - resistance battery circuit is switched on at $t = 0$. If the emf of the battery is E. The charge which passes through the battery in one time constant τ will be-
- (1) $i_0 \tau/e$
 - (2) $i_0 e/\tau$
 - (3) $\tau e/i_0$
 - (4) $i_0 e \tau$
- Q.9** Two conducting circular loops of radii R_1 and R_2 are placed in the same plane with their centres coinciding. The mutual inductance between them assuming $R_2 \ll R_1$, will be-
- (1) $\frac{\mu_0 \pi R_2^2}{2R_1}$
 - (2) $\frac{\mu_0 R_2^2}{2R_1}$
 - (3) $\frac{\mu_0 R_2}{2R_1}$
 - (4) $\frac{\mu_0 \pi R_2^2}{2R_1^2}$

- Q.10** A conductor rod AB moves parallel to X-axis in a uniform magnetic field, pointing in the positive Z-direction. The end A of the rod gets-

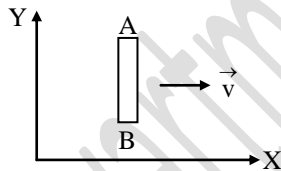

- (1) positively charged
 - (2) negatively charged
 - (3) neutral
 - (4) first positively charged and then negatively charged
- Q.11** A closed coil of copper whose area is $1\text{m} \times 1\text{m}$ is free to rotate about an axis. The coil is placed perpendicular to a magnetic field of 0.10 Wb/m^2 . It is rotated through 180° in 0.01 second. The induced e.m.f. and induced current in the coil will respectively be-
- (The resistance of the coil is 2.0Ω)
- (1) 20 V, 10A
 - (2) 10 V, 20 A
 - (3) 10 V, 10 A
 - (4) 20 V, 20 A

- Q.12** A bicycle wheel of radius 0.5 m has 32 spokes. It is rotating at the rate of 120 revolutions per minute, perpendicular to the horizontal component of earth's magnetic field $B_H = 4 \times 10^{-5}$ Tesla. The emf induced between the rim and the centre of the wheel will be-

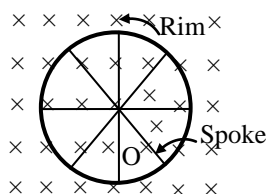

Some important numerical problems on electromagnetic induction

- (1) $6.28 \times 10^{-5} \text{ V}$ (2) $4.8 \times 10^{-5} \text{ V}$
(3) $6.0 \times 10^{-5} \text{ V}$ (4) $1.6 \times 10^{-5} \text{ V}$

- Q.13** The current in a coil varies with respect to time t as $I = 3t^2 + 2t$. If the inductance of coil be 10 mH, the value of induced e.m.f. at $t = 2\text{s}$ will be-
- (1) 0.14 V (2) 0.12 V
(3) 0.11 V (4) 0.13 V
- Q.14** If circular coil with N_1 turns is changed in to a coil of N_2 turns. What will be the ratio of self inductances in both cases-
- (1) $\frac{N_1}{N_2}$ (2) $\frac{N_2}{N_1}$
(3) $\frac{N_1^2}{N_2^2}$ (4) $\sqrt{\frac{N_1}{N_2}}$
- Q.15** A solenoid has an inductance of 50 mH and a resistance of 0.025Ω . If it is connected to a battery, how long will it take for the current to reach one half of its final equilibrium value ?
- (1) 1.34 s (2) 1.2 s
(3) 6.32 s (4) 0.23 s
- Q.16** 5.5×10^{-4} magnetic flux lines are passing through a coil of resistance 10 ohm and number of turns 1000. If the number of flux lines reduces to 5×10^{-5} in 0.1 sec. The electromotive force and the current induced in the coil will be respectively-
- (1) 5V, 0.5 A
(2) $5 \times 10^{-4} \text{ V}$, $5 \times 10^{-4} \text{ A}$
(3) 50 V, 5 A
(4) none of the above
- Q.17** A closed coil consists of 500 turns on a rectangular frame of area 4.0 cm^2 and has a resistance of 50 ohm. The coil is kept with its plane perpendicular to a uniform magnetic field of $0.2 \text{ Weber/meter}^2$. The amount of charge flowing through the coil if it is turned over (rotated through 180°) will be -
- (1) $1.6 \times 10^{-19} \text{ C}$ (2) $1.6 \times 10^{-9} \text{ C}$
(3) $1.6 \times 10^{-3} \text{ C}$ (4) $1.6 \times 10^{-2} \text{ C}$
- Q.18** When the current through a solenoid increases at a constant rate, the induced current-
- (1) is a constant and is in the direction of the inducing current
(2) is a constant and is opposite to the direction of the inducing current
(3) increase with time and is in the direction of the inducing current
(4) increase with time and opposite to the direction of the inducing current
- Q.19** According to Faraday's Laws of electro magnetic induction-
- (1) The direction of the induced current is such that it opposes itself
(2) The induced emf in the coil is proportional to the rate of change of magnetic flux associated with it
(3) The direction of induced emf is such that it opposes it self
(4) None of the above
- Q.20** A coil having an area of 2m^2 is placed in a magnetic field which changes from 1 Weber/m^2 to 4 Weber/m^2 in 2 seconds. The e.m.f. induced in the coil will be-

Some important numerical problems on electromagnetic induction

- (1) 4 volt (2) 3 volt
(3) 2 volt (4) 1 volt

- Q.21** A conducting loop is placed in an uniform magnetic field with its plane perpendicular to the field. An emf is induced in the loop if-
- (a) It is translated within magnetic field
(b) It is rotated about its axis
(c) It is rotated about a diameter
(d) It is deformed
- (1) b,c (2) b,d (3) c, d (4) a,c,d

- Q.22** Two co-axial solenoids shown in figure. If key of primary suddenly opened then direction of instantaneous induced current in resistance 'R' which connected in secondary-

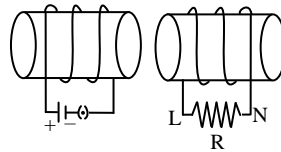

- (1) L to N (2) N to L
(3) Alternating (4) Zero

- Q.23** Magnetic flux through a coil is changes with respect to time then emf induced in it which incorrect regarding induced emf in coil-
- (1) Coil may be made up with wood
(2) Coil may be connected with an open circuit
(3) Coil must be of conducting nature
(4) Induced emf does not depends upon resistance of the coil

- Q.24** The current flows in a circuit as shown below. If a second circuit is brought near the first circuit then the current in the second circuit will be-

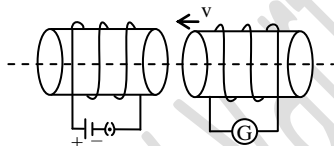

- (1) Clock wise
(2) Anti clock wise
(3) Depending on the value of R_G
(4) None of the above

- Q.25** Two identical circular coils A and B are placed parallel to each other with their centres on the same axis. The coil B carries a current I in the clock wise direction as seen from A. What would be the direction of the induced current in A seen from B when-
- (a) The current in B is increased ?
(b) The coil B is moved towards A keeping the current in B constant ?
- (1) clockwise, clockwise
(2) clockwise, anticlockwise
(3) anti clockwise, clockwise
(4) anticlockwise, anticlockwise

- Q.26** An emf induced in a coil, the linking magnetic flux-
- (1) Must decrease
(2) Must increase
(3) Must remain constant

Some important numerical problems on electromagnetic induction

(4) Can either increase or decrease

Q.27 A coil of resistance 10Ω and 1000 turns have the magnetic flux line of 5.5×10^{-4} Wb. If the magnetic flux changed 5×10^{-4} Wb in 0.1 sec, then the induced charge in coil is-

- (1) $50 \mu\text{C}$ (2) $5 \mu\text{C}$
 (3) $2 \mu\text{C}$ (4) $20 \mu\text{C}$

Q.28 One coil of resistance 40Ω is connected to a galvanometer of 160Ω resistance. The coil has radius 6mm and turns 100. This coil is placed between the poles of a magnet such that magnetic field is perpendicular to coil. If coil is dragged out then the charge through the galvanometer is $32 \mu\text{C}$. The magnetic field is-

- (1) 6.55 T (2) 5.66 T
 (3) 0.655 T (4) 0.566 T

Q.29 A flexible wire bent in the form of a circle is placed in a uniform magnetic field perpendicular to the plane of the coil. The radius of the coil changes as shown in figure. The induced emf in the coil is-

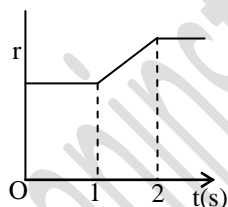

- (1) (2)
 (3) (4)

Q.30 A short bar magnet passes at a steady speed right through a long solenoid. A galvanometer is connected across the solenoid. Which graph best represents the variation of the galvanometer deflection θ with time ?

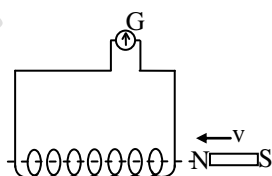

- (1) (2)

Some important numerical problems on electromagnetic induction

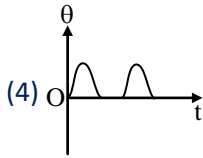
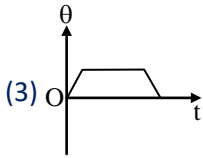

- Q.31** A square loop of side 22 cm is changed to a circle in time 0.4 s. The magnetic field present is 0.2 T. The emf induced is-
- (1) – 6.6 mV (2) – 13.2 mV
(3) + 6.6 mV (4) + 13.2 mV
- Q.32** The magnetic flux in a coil of 100 turns increases by 12×10^3 Maxwell in 0.2 s due to the motion of a magnet. The emf induced in the coil will be-
- (1) 0.6 mV (2) 0.6 V
(3) 6 V (4) 60 V
- Q.33** Which one of the following can produce maximum induced emf-
- (1) 50 ampere dc
(2) 50 ampere 50 Hz ac
(3) 50 ampere 500 Hz ac
(4) 100 ampere dc
- Q.34** A solenoid of 10 henry inductance and 2 ohm resistance is connected to a 10 volt battery. In how much time the magnetic energy will be increases to $1/4^{\text{th}}$ of the maximum value ?
- (1) 3.5 sec (2) 2.5 sec
(3) 5.5 sec (4) 7.5 sec
- Q.35** An inductance coil have the time constant 4 sec, if it is cut into two equal parts and connected parallel then new time constant of the circuit-
- (1) 4 sec (2) 2 sec
(3) 1 sec (4) 0.5 sec
- Q.36** Which statement is correct from following-
- (a) inductor store energy in the form of magnetic field
(b) capacitor store energy in the form of electric field
(c) inductor store energy in the form of electric and magnetic field both
(d) capacitor store energy in the form of electric and magnetic field both
- (1) a, b (2) a, c (3) b, d (4) b, c
- Q.37** Two coils are made of copper wires of same length. In the first coil the number of turns is $3n$ and radius is r . In the second coil number of turns is n and radius is $3r$ the ratio of self inductances of the coils will be-
- (1) 9 : 1 (2) 3 : 1 (3) 1 : 3 (4) 1 : 9
- Q.38** If a current of 2A give rise in a magnetic flux of 5×10^{-5} weber/turn through a coil having 100 turns, then the magnetic energy stored in the medium surrounding by the coil is-
- (1) 5 joule (2) 5×10^{-7} joule
(3) 5×10^{-3} joule (4) 0.5 joule
- Q.39** For a solenoid keeping the turn density constant its length makes halved and its cross section radius is doubled then the inductance of the solenoid increased by-
- (1) 200% (2) 100% (3) 800% (4) 700%
- Q.40** In the circuit shown in figure bulb will become suddenly bright if-

Some important numerical problems on electromagnetic induction

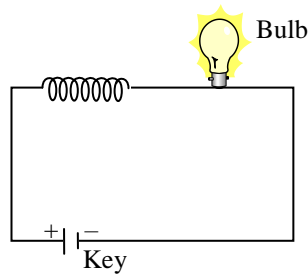

- (1) key is closed
- (2) key is opened
- (3) key is opened or closed
- (4) would not become bright

Q.41 Two bulb of same rating B_1 and B_2 are connected in series with the inductors as shown in figure which bulb take more time to light at maximum brightness-

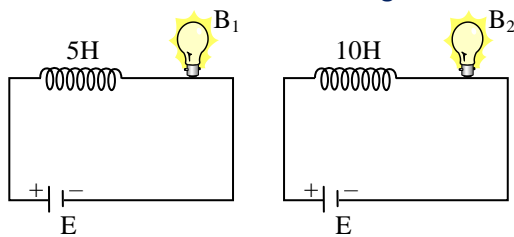

- (1) B_1
- (2) B_2
- (3) Both take same time
- (4) None

Q.42 A constant current i maintained in a solenoid. Which of the following quantities will increase if an iron rod is inserted in the solenoid along it axis-

- (a) magnetic field at the centre
 - (b) magnetic flux linked with the solenoid
 - (c) self inductance of the solenoid
 - (d) rate of joule heating
- (1) a, b, c
 - (2) c, d
 - (3) a, b
 - (4) only b

Q.43 A coil of copper wire is connected in series with a bulb, a battery and a switch. When the circuit is completed the bulb lights up immediately. The circuit is switched off and a rod of soft iron is placed inside the coil. On completing the circuit again. It is observed that-

- (1) Bulb is not so bright
- (2) There is a slight delay before bulb lights to its normal brightness
- (3) The bulb is initially bright but gradually becomes dim
- (4) The bulb is brighter than before

Q.44 The inductance of a solenoid is 5 henry and its resistance is 5Ω . If it is connected to a 10 volt battery then time taken by the current to reach $9/10^{\text{th}}$ of its maximum will be-

- (1) 4.0 s
- (2) 2.3 s
- (3) 1.4 s
- (4) 1.2 s

Q.45 When a certain circuit consisting of a constant emf E , an inductance L and a resistance R is closed, the current in it increases with time according to curve 1. After one parameter (E , L or R) is changed, the increase in current follows curve 2, when the circuit is closed second time. Which parameter was changed and in what direction-

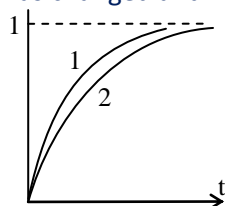

Some important numerical problems on electromagnetic induction

- (1) L is increased (2) L is decreased
 (3) R is increased (4) R is decreased

Q.46 An LR circuit with a battery is connected at $t = 0$. Which of the following quantities is not zero just after the connection ?

- (a) current in circuit
 (b) magnetic potential energy in the inductor
 (c) power delivered by the battery
 (d) emf induced in the inductor
 (1) a, b (2) a, c
 (3) c, d (4) only d

Q.47 During 0.1 sec current in a coil increases from 1A to 1.5A. If inductance of this coil is $60\mu\text{H}$, induced current in external resistance of $600\mu\Omega$ is-

- (1) 1 A (2) $\frac{4}{3}$ A
 (3) $\frac{2}{3}$ A (4) $\frac{1}{2}$ A

Q.48 A closely wound coil of 100 turns and area of cross section 1 cm^2 has a self inductance 1mH. The magnetic induction at the centre of the coil, when a current of 2A flows in it, will be-

- (1) $0.2 \frac{\text{Wb}}{\text{m}^2}$
 (2) $0.4 \frac{\text{Wb}}{\text{m}^2}$
 (3) $0.8 \frac{\text{Wb}}{\text{m}^2}$
 (4) $1 \frac{\text{Wb}}{\text{m}^2}$

Q.49 In the circuit shown in figure what is the value of I_1 just after pressing the key K ?

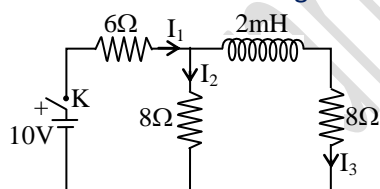

- (1) $\frac{5}{7}$ A (2) $\frac{5}{11}$ A
 (3) 1A (4) None of the above

Q.50 Pure inductors each of inductance 3 H are connected as shown. The equivalent inductance of the circuit is-

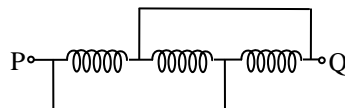

- (1) 1H (2) 2H (3) 3H (4) 9H

Q.51 The time constant of an inductance coil is 2.0×10^{-3} s. When a 90Ω resistance is joined in series, the time constant becomes 0.5×10^{-3} s. The inductance and resistance of the coil are-

- (1) 30 mH ; 30Ω (2) 30 mH ; 60Ω
 (3) 60 mH ; 30Ω (4) 60 mH ; 60Ω

Some important numerical problems on electromagnetic induction

- Q.52** A toroidal solenoid with an air core has an average radius of 15 cm, area of cross-section 12 cm^2 and 1200 turns. Ignoring the field variation across the cross-section of the toroid, the self-inductance of the toroid is-
- (1) 4.6 mH (2) 6.9 mH
(3) 2.3 mH (4) 9.2 mH

- Q.53** A circular iron, core supports N turns. If a current I produces a magnetic flux ϕ across the core's cross section, then the magnetic energy is-
- (1) $I\phi$ (2) $\frac{1}{2} I\phi$ (3) $\frac{1}{3} I\phi$ (4) $I^2\phi$

- Q.54** The self inductance of a toroid is-
- (1) $\frac{\mu_0 N^2 r^2}{2R_m}$ (2) $\frac{\mu_0 N^2 \pi r}{2R_m}$
(3) $\frac{\mu_0 N^2 r}{2R_m}$ (4) $\frac{\mu_0 N^2 r \pi}{2R_m}$

- Q.55** In fig.(a) and fig.(b) two air-cored solenoids P and Q have been shown. They are placed near each other. In fig.(a), when I_p , the current in P, changes at the rate of 5 A/s, an emf of 2mV is induced in Q. The current in P is then switched off, and a current changing at 2 A/s is fed through Q as shown in diagram. What emf will be induced in P-

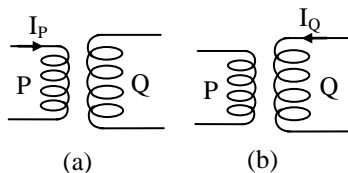

- (1) $8 \times 10^{-4} \text{ V}$ (2) $2 \times 10^{-8} \text{ V}$
(3) $5 \times 10^{-3} \text{ V}$ (4) $8 \times 10^{-2} \text{ V}$

- Q.56** A small square loop of wire of side ℓ is placed inside a large square loop of wire of side $L(L \gg \ell)$. The loops are coplanar and their centres coincide. The mutual inductance of the system is proportional to-
- (1) $\frac{\ell}{L}$ (2) $\frac{\ell^2}{L}$
(3) $\frac{L}{\ell}$ (4) $\frac{L^2}{\ell}$

- Q.57** An athlete runs at a velocity of 30 km/hr towards east with a 3 meter rod. The horizontal component of the earth is $4 \times 10^5 \text{ weber/m}^2$. If he runs, keeping the rod (i) horizontal and (ii) vertical, the potential difference between the ends of the rod in both the cases, will be-
- (1) Zero in vertical case and $1 \times 10^{-3} \text{ V}$ in the horizontal case
(2) $1 \times 10^{-3} \text{ V}$ in vertical case and zero in the horizontal case
(3) Zero in both the cases
(4) $1 \times 10^{-3} \text{ V}$ in both cases

- Q.58** A 10 m long copper wire while remaining in the east-west horizontal direction is falling down with a constant speed of 5.0 m/s. If the horizontal component of the earth's magnetic field $0.3 \times 10^{-4} \text{ Weber/m}^2$, the e.m.f. developed between the ends of the wire is-
- (1) 0.15 volt (2) 1.5 volt
(3) 0.15 milli volt (4) 1.5 milli volt

- Q.59** A conducting rod of length 2ℓ is rotating with constant angular speed ω about its perpendicular bisector. A uniform magnetic field \vec{B} exists parallel to the axis of rotation. The emf induced between two ends of the rod is-

Some important numerical problems on electromagnetic induction

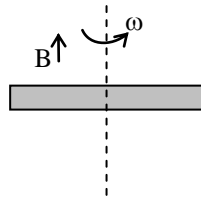

- (1) $B\omega\ell^2$ (2) $\frac{1}{2}B\omega\ell^2$
(3) $\frac{1}{8}B\omega\ell^2$ (4) Zero

Q.60 A conducting rod of 1m length rotating with a frequency of 50 rev/sec about its one of end inside the uniform magnetic field of 6.28 mT. The value of induced emf between end of rod is-

(1) 1 V (2) 2 V
(3) 0.5 V (4) 0.25 V

Q.61 A semicircle loop PQ of radius 'R' is moved with velocity 'v' in transverse magnetic field as shown in figure. The value of induced emf between the ends of loop is-

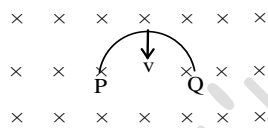

- (1) $Bv(\pi r)$, end 'P' at high potential
(2) $2BRv$, end 'P' at high potential
(3) $2BRv$, end 'Q' at high potential
(4) $B \frac{\pi R^2}{2} v$, end 'P' at high potential

Q.62 A car moves up on a plane road. The induced emf in axle connecting the two wheels is maximum when it moves-

(1) At the poles
(2) At the equator
(3) Remain stationary
(4) At the equator and poles both

Q.63 If an artificial satellite with metal surface is moving in the equatorial plane of earth, then the e.m.f. induced in it due to earth's magnetism will be-

(1) Negative and the base towards earth
(2) Positive and the base towards earth
(3) No emf induced
(4) None of the above

Q.64 Which statement is not correct-

(1) Inductance is not possible without resistance
(2) Resistance is possible without inductance
(3) Sparking is occur due to high inductance
(4) An aeroplane is flying at equator there is induction of emf across the wings

Q.65 A metal aeroplane having a distance of 50 meter between the tips of its wings is flying horizontally with a speed of 360 km/hour. At the place of flight, the earth's total magnetic field is $4.0 \times 10^{-5} \text{ W/m}^2$ and the angle of dip is 30° . Find out the induced potential difference between the tips of its wings. If a bulb is connected across the edges of the wings, will it light up ?

(1) 0.1 volt, bulb will be light up
(2) 0.2 volt, bulb will be light up
(3) 0.1 volt, bulb will not light up

Some important numerical problems on electromagnetic induction

(4) 0.2 volt, bulb will not light up

Q.66 The loop shown moves with a constant velocity 'v' in a uniform magnetic field of magnitude 'B' directed into the paper. The potential difference between P and Q is 'e' -

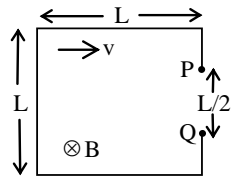

- (1) $e = \frac{1}{2} BLv$, Q is positive with respect to P (2) $e = \frac{BLv}{2}$, P is positive with respect to Q
 (3) $e = 0$ (4) $e = BLv$, Q is positive with respect to P

Q.67 A conducting wheel in which there are four rods of length ℓ as shown in figure is rotating with angular velocity ω in a uniform magnetic field B. The induced potential difference between its centre and rim will be-

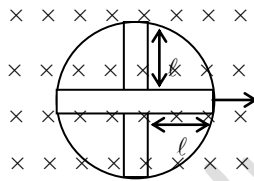

- (1) $2B\omega\ell^2$ (2) $\sqrt{B\ell^2\omega}$
 (3) $\frac{B\ell\omega}{2}$ (4) $\frac{B\ell^2\omega}{2}$

Q.68 A conducting rod rotates with a constant angular velocity ' ω ' about the axis which passes through point 'O' and perpendicular to its length. A uniform magnetic field 'B' exists parallel to the axis of the rotation. Then potential difference between the two ends of the rods is-

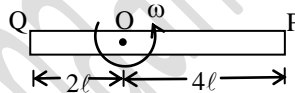

- (1) $6B\omega\ell^2$ (2) $B\omega\ell^2$
 (3) $10B\omega\ell^2$ (4) zero

Q.69 Two long parallel metallic wires with a resistance 'R' form a horizontal plane. A conducting rod AB is on the wires shown in figure. The space has magnetic field pointing vertically downwards. The rod is given an initial velocity ' v_0 '. There is no friction in the wires and the rod. After a time 't' the velocity v of the rod will be such that-

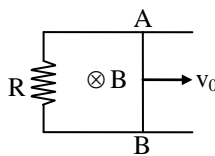

- (1) $v > v_0$ (2) $v < v_0$
 (3) $v = v_0$ (4) $v = -v_0$

Q.70 If a bar magnet is dropped vertically into a long copper tube then its final acceleration will be-

- (1) $a = g$ (2) $a > g$
 (3) $a < g$ (4) $a = 0$

Q.71 A closed coil consists of 500 turns on a rectangular frame of area 4.0 cm^2 and has a resistance of 50 ohms. The coil is kept with its plane perpendicular to a uniform magnetic field of 0.2 wb/m^2 , the amount of charge flowing through the coil if it is turned over (rotated through 180°) -

- (1) $1.6 \times 10^{-3} \text{ C}$ (2) $16 \times 10^{-3} \text{ C}$
 (3) $0.16 \times 10^{-3} \text{ C}$ (4) $160 \times 10^{-3} \text{ C}$

Some important numerical problems on electromagnetic induction

- Q.72** A coil of mean area 500 cm^2 and having 1000 turns is held perpendicular to a uniform field of 0.4 gauss. The coil is turned through 180° in $\frac{1}{10}$ second. The average induced e.m.f. -
- (1) 0.04 V (2) 0.4 V
(3) 4 V (4) 0.004 V

- Q.73** A current time curve is shown in the following diagram. This type of current is passed in the primary coil of transformer. The nature of induced emf in the secondary coil will be-

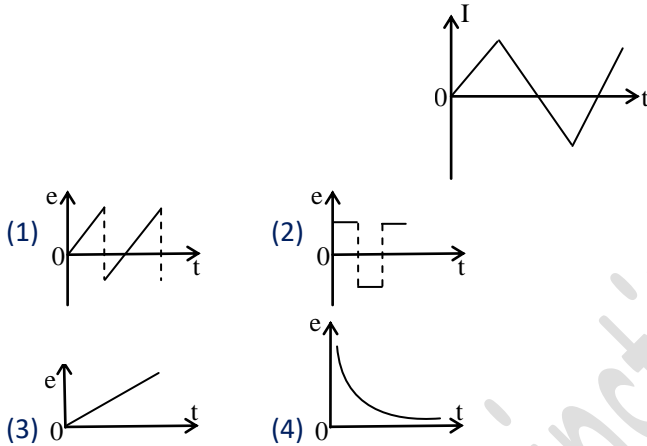

- Q.74** The armature coil of dynamo is in motion. The generated induced emf varies and the number of magnetic lines of force also varies. Which of the following condition is correct-
- (1) lines of flux will be minimum, but induced emf will be zero
(2) lines of flux will be maximum, but the induced emf will be zero
(3) lines of flux will be maximum, but induced emf will not be zero
(4) the lines of flux will be maximum, and the induced emf will be also maximum

- Q.75** A simple electric motor has an armature resistance of 1Ω and runs from a dc source of 12 volt. When running unloaded it draws a current of 2amp when a certain load is connected, its speed becomes one-half of its unloaded value. The new value of current drawn-
- (1) 7 A (2) 2 A (3) 5 A (4) 3 A

- Q.76** A d.c. motor has internal resistance 4 ohms. It is operated at 220 volts and draws 5 ampere current. The useful mechanical power developed is-
- (1) 550 W (2) 100 W
(3) 1100 W (4) 1000 W

- Q.77** An electric motor runs on a D.C., sources of emf. E and internal resistance 'r'. Then the power out put of source is maximum when the armature current (Suppose resistance of armature is zero) -
- (1) $\frac{E}{r}$ (2) $\frac{E}{2r}$ (3) ∞ (4) 0

- Q.78** A transformer is used to-
- (1) change the alternating potential
(2) change the alternating current
(3) to prevent the power loss
(4) to increase the power of current source

Some important numerical problems on electromagnetic induction

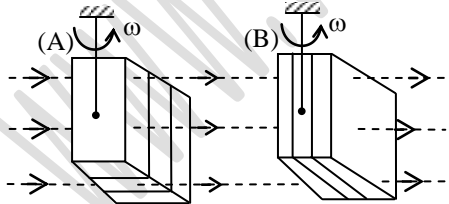
- Q.79** Large transformer, when used for some time becomes hot and are cooled by circulating oil. the heating of transformer is due to-
- (1) heating effect of current alone
 - (2) hysteresis loss alone
 - (3) eddy currents losses alone
 - (4) all of above
- Q.80** For same rating which have the maximum efficiency from following-
- (1) Motor
 - (2) Transformer
 - (3) D.C. generator
 - (4) A.C. generator
- Q.81** If 2.2 kW power transmits 22000 volts in a line of 10Ω resistance, the value of power loss will be-
- (1) 0.1 watt
 - (2) 14 watts
 - (3) 100 watts
 - (4) 1000 watts
- Q.82** If a transformer have turn ratio 5, frequency 50 Hz root mean square value of potential difference on primary 100 volts and the resistance of the secondary winding is 500Ω then the peak value of voltage in secondary winding will be (the efficiency of the transformer is hundred percent) -
- (1) $500\sqrt{2}$
 - (2) $10\sqrt{2}$
 - (3) $50\sqrt{2}$
 - (4) $20\sqrt{2}$
- Q.83** Plane of eddy circulations makes an angle with the external time varying magnetic field is-
- (1) 0°
 - (2) 45°
 - (3) 180°
 - (4) 90°
- Q.84** Eddy current do not cause-
- (1) Sparking
 - (2) Loss of energy
 - (3) Damping
 - (4) Heating
- Q.85** When a metallic sphere is moved in a magnetic field, it gets heated due to-
- (1) Direct current
 - (2) Eddy currents
 - (3) Alternating current
 - (4) Additional current
- Q.86** Two copper cubes A and B composed of identical insulated plates are suspended from strings in between the pole pieces of an electromagnet. Both cubes are rotating at the same angular velocity. The electromagnet is energies when we switched on the electro magnet, the cube that will come to rest letter is-
- 
- (1) A (2) B
(3) Both A and B (4) None of these
- Q.87** A bar magnet is dropped into a vertical copper tube, considering the air resistance as negligible, the magnet acquired a constant speed. If the tube is heated the terminal velocity will be-
- (1) Decrease
 - (2) Increase
 - (3) Remain unchanged
 - (4) Data's are incomplete

IMPORTANT PRACTICE QUESTION SERIES FOR IIT-JEE EXAM - 3

- Q.1** A magnet is allowed to fall through a metal ring. During fall its acceleration will be-
- (1) equal to g
(2) greater than g
(3) less than g
(4) less than or greater than g depending on which pole is pointing downwards
- Q.2** An ideal transformer is used on 220 V line to deliver 2A at 110 V. The current through the primary is-
- (1) 10A (2) 5A
(3) 1A (4) 0.1A
- Q.3** Which of the following combination has the dimension of time-
- (1) R/L (2) LC
(3) $1/LC$ (4) L/R
- Q.4** The primary winding of a transformer has 500 turns whereas its secondary has 5000 turns. The primary is connected to a supply of 20V, 50 Hz. The secondary will have an output of-
- (1) 200 V, 50 Hz (2) 2 V, 50 Hz
(3) 200 V, 500 Hz (4) 2 V, 5 Hz
- Q.5** Two coil have a mutual inductance 0.005 H. The current changes in first coil according to equation $I = I_0 \sin \omega t$, where $I_0 = 2A$ and $\omega = 100\pi$ rad/sec. The maximum value of induced emf in second coil is-
- (1) $4\pi V$ (2) $3\pi V$
(3) $2\pi V$ (4) πV
- Q.6** Turn ratio of a step-up transformer is 1 : 25. If current in load coil is 2A, then the current in primary coil will be-
- (1) 25A (2) 50A
(3) 0.25A (4) 0.5A
- Q.7** Initially plane of coil is parallel to the uniform magnetic field B . In time Δt it makes to perpendicular to the magnetic field, then charge flows through the coil depends on this time as-
- (1) $\propto \Delta t$ (2) $\propto \frac{1}{\Delta t}$
(3) $\propto (\Delta t)^0$ (4) $\propto (\Delta t)^2$
- Q.8** For an inductor coil $L = 0.04$ H, then work done by source to establish a current of 5A in it is-
- (1) 0.5 J (2) 1.00 J
(3) 100 J (4) 20 J
- Q.9** For a coil having $L = 2$ mH, current flow through it is $I = t^2 e^{-t}$ then the time at which induced emf become zero-
- (1) 2 sec (2) 1 sec
(3) 4 sec (4) 3 sec

Some important numerical problems on electromagnetic induction

Q.10 The magnetic flux through a circuit of resistance R changes by an amount $\Delta\phi$ in a time Δt . The total quantity of electric charge Q that passes any point in the circuit during the time Δt is represented by-

- (1) $Q = \frac{\Delta\phi}{R}$ (2) $Q = \frac{\Delta\phi}{\Delta t}$
(3) $Q = R \cdot \frac{\Delta\phi}{\Delta t}$ (4) $Q = \frac{1}{R} \cdot \frac{\Delta\phi}{\Delta t}$

Q.11 A coil of 40 henry inductance is connected in series with a resistance of 8 ohm and the combination is joined to the terminals of a 2 volt battery. The time constant of the circuit is-

- (1) $\frac{1}{5}$ sec
(2) 40 sec
(3) 20 sec
(4) 5 sec

Q.12 As a result of change in the magnetic flux linked to the closed loop shown in the figure, an e.m.f. V volt is induced in the loop. The work done (joules) in taking a charge Q coulomb once along the loop is-

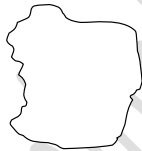

- (1) QV (2) $QV/2$ (3) $2QV$ (4) Zero

Q.13 Two coils of self inductances 2mH and 8 mH are placed so close together that the effective flux in one coil is completely linked with the other. The mutual inductance between these coils is-

- (1) 10 mH (2) 6 mH (3) 4 mH (4) 16 mH

Q.14 The primary and secondary coils of a transformer have 50 and 1500 turns respectively. If the magnetic flux ϕ linked with the primary coil is given by $\phi = \phi_0 + 4t$, where ϕ is in webers, t is time in seconds and ϕ_0 is a constant, the output voltage across the secondary coil is-

- (1) 30 volts (2) 90 volts
(3) 120 volts (4) 220 volts

Q.15 A transformer is used to light a 100 W and 110 V lamp from a 220 V mains. If the main current is 0.5 amp, the efficiency of the transformer is approximately-

- (1) 10% (2) 30% (3) 50% (4) 90%

Q.16 An electric bulb in series with a large inductor when connected across a DC source take a little time before reaching a stable glow. If an iron core is inserted to the inductor, the delay will-

- (1) increases
(2) decreases
(3) remain the same
(4) may change in either direction depending upon the values of inductance and resistance

Q.17 The device that does not work on the principle of mutual induction is-

- (1) motor (2) tesla coil
(3) transformer (4) induction coil

Q.18 To induce an emf in a coil, the magnetic flux linking-

Some important numerical problems on electromagnetic induction

- (1) can either increase or decrease
- (2) must remain constant
- (3) must increase
- (4) must decrease

Q.19 The bob of a simple pendulum is replaced by a magnet. The oscillation are set along the length of the magnet. A copper coil is added so that one pole of the magnet passes in and out of the coil. The coil is shortcircuited. Then which of the following happens ?

- (1) period does not change
- (2) oscillations are damped
- (3) amplitude increases
- (4) period decreases

Q.20 A coil of copper having 1000 turns is placed in a magnetic field ($B = 4 \times 10^{-3}$ T) perpendicular to its plane. The cross sectional area of the coil is 0.05 m^2 . If it turns through 180° in 0.01 sec, then the induced emf in the coil is-

- (1) 0.4 V (2) 0.2 V (3) 40 V (4) 4 V

Q.21 In Lenz's law, there is conservation of-

- (1) charge (2) momentum
- (3) energy (4) current

Q.22 If the rotational velocity of a dynamo armature is doubled, then induced e.m.f. will become-

- (1) half (2) two times
- (3) four times (4) unchanged

Q.23 The north pole of a magnet is brought near a metallic ring. The direction of the induced current in the ring will be-

- (1) clockwise (2) anticlockwise
- (3) towards north (4) towards south

Q.24 The current flows from A to B as shown in the figure. The direction of the induced current in the loop is-

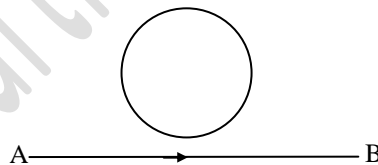

- (1) clockwise (2) anticlockwise
- (3) straight line (4) none of these

Q.25 The mutual inductance of two coils when magnetic flux changes by 2×10^{-2} Wb and current changes by 0.01 A is-

- (1) 2 H (2) 3 H (3) 4 H (4) 8 H

Q.26 A conducting ring of radius 1 meter is placed in an uniform magnetic field B of 0.01 T, oscillating with frequency 100 Hz with its plane at right angles to magnetic field. What will be the induced electric field-

- (1) π volts/m (2) 2π volts/m
- (3) 10 volts/m (4) 62 volts/m

Q.27 A magnet is made to oscillate with a particular frequency, passing through a coil as shown in figure. The time variation of the magnitude of e.m.f. generated across the coil during one cycle is-

Some important numerical problems on electromagnetic induction

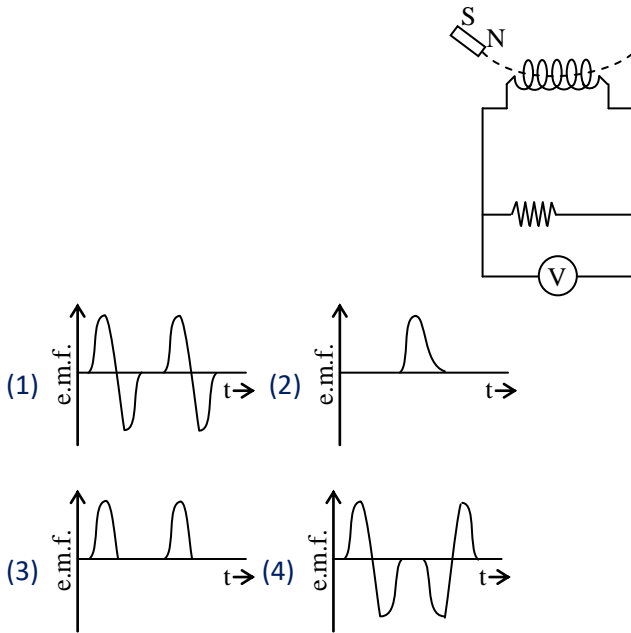

Q.28 A metallic ring is dropped down, keeping its plane perpendicular to a constant and horizontal magnetic field. The ring enters the region of magnetic field at $t = 0$ and completely emerges out at $t = T$ sec. The current in the ring varies as-

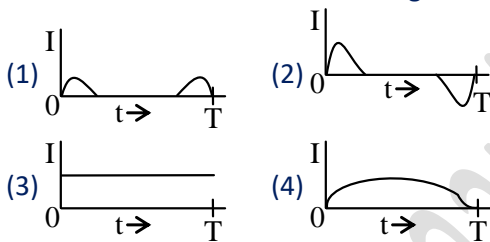

Q.29 The current passing through a choke coil of 5H is decreasing at the rate of 2 amp./sec. The e.m.f. developing across the coil is-
 (1) 10 V (2) -10 V (3) 2.5 V (4) -2.5 V

Q.30 Transformer works on the basis of the following phenomenon-
 (1) Self-induction
 (2) Mutual induction
 (3) Electrical discharge
 (4) Generation of electro-magnetic waves

Q.31 A long solenoid has 500 turns. When a current of 2 ampere is passed through it, the resulting magnetic flux linked with each turn of the solenoid is 4×10^{-3} wb. The self-inductance of the solenoid is-
 (1) 1.0 henry (2) 4.0 henry
 (3) 2.5 henry (4) 2.0 henry

Q.32 A conducting circular loop is placed in a uniform magnetic field 0.04 T with its plane perpendicular to the magnetic field. The radius of the loop starts shrinking at 2 mm/s. The induced emf in the loop when the radius is 2 cm is-
 (1) $3.2 \pi \mu\text{V}$ (2) $4.8 \pi \mu\text{V}$
 (3) $0.8 \pi \mu\text{V}$ (4) $1.6 \pi \mu\text{V}$

Q.33 A rectangular, a square, a circular and an elliptical loop, all in the (x - y) plane, are moving out of a uniform magnetic field with a constant velocity, $\vec{V} = v\hat{i}$. The magnetic field is directed along the negative z-axis direction. The induced emf, during the passage of these loops, come out of the field region, will not remain constant for-

Some important numerical problems on electromagnetic induction

- (1) the rectangular, circular and elliptical loops
- (2) the circular and the elliptical loops
- (3) only the elliptical loop
- (4) any of the four loops

Q.34 A conducting circular loop is placed in a uniform field, $B = 0.025 \text{ T}$ with its plane perpendicular to the loop. The radius of the loop is made to shrink at a constant rate of 1 mm/s . The induced e.m.f. when the radius is 2 cm , is-

- (1) $2 \mu\text{V}$ (2) $2\pi\mu\text{V}$ (3) $\pi\mu\text{V}$ (4) $\frac{\pi}{2} \mu\text{V}$

Q.35 A 220-volt input is supplied to a transformer. The output circuit draws a current of 2.0 ampere at 440 volts. If the efficiency of the transformer is 80%, the current drawn by the primary windings of the transformer is-

- (1) 5.0 ampere (2) 3.6 ampere
- (3) 2.8 ampere (4) 2.5 ampere

Q.36 The current i in a coil varies with time as shown in the figure. The variation of induced emf with time would be :

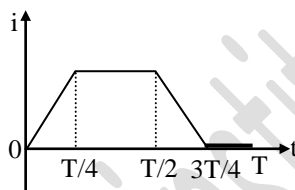

- (1)
- (2)
- (3)
- (4)

IMPORTANT PRACTICE QUESTION SERIES FOR IIT-JEE EXAM - 4

Q.1 Dimension of a rectangular coil is $20 \text{ cm} \times 10 \text{ cm}$. Number of turns in coil is 60. It is rotating about its one of the diameter in an uniform magnetic field of 0.5 T , with a speed 1800 r.p.m the maximum induced e.m.f. is-

- (1) 98 V (2) 100 V (3) 113 V (4) 118 V

Some important numerical problems on electromagnetic induction

- Q.2** Number of turns in primary coil of a transformer is 240. When input voltage is 20 volt, then output voltage is 2.5 volt. The number of turns in secondary coil is-
(1) 250 (2) 100 (3) 10 (4) 30
- Q.3** Side of a square coil is 4 cm. A magnetic field normal to plane of coil is changing at a rate of 0.4 tesla/sec. If resistance of coil is 2×10^{-3} ohm, then induced current is-
(1) 0.16 A (2) 0.32 A
(3) 3.2 A (4) 1.6 A
- Q.4** The induced e.m.f. in a L-R circuit is maximum-
(1) at the time of switching on due to high inductance
(2) at the time of switching off due to high inductance
(3) at the time of switching off due to low inductance
(4) at the time of switching on due to low inductance
- Q.5** The ratio of number of turns in secondary and primary coils of step up transformer is 4 : 1. If the current in the primary coil is 4 amp. The current in the secondary coil is-
(1) 8 A (2) 2 A (3) 1 A (4) 0.5 A
- Q.6** A long wire is in north-south direction, it is dropped freely towards earth, then no potential difference is induced between its ends. This statement is-
(1) true (2) false
(3) meaningless (4) none of these
- Q.7** Lenz's law is based on-
(1) conservation of energy
(2) conservation of mass
(3) conservation of linear momentum
(4) conservation of angular momentum
- Q.8** By which law, direction of induced current can be found-
(1) Ampere's law (2) Fleming's law
(3) Faraday's law (4) Lenz's law
- Q.9** In a secondary coil of a step up transformer-
(1) less turns of thin wire
(2) more turns of thin wire
(3) less turns of thick wire
(4) more turns of thick wire
- Q.10** An a.c. of 50 Hz and 1 A peak value flows in the primary coil of a transformer. The mutual inductance between primary and secondary coils is 1.5 H. Then peak value of induced emf across secondary coil is-
(1) 75π volt (2) 150π volt
(3) 225 volt (4) 300 volt
- Q.11** When a current changes from 2A to 4A in 0.05 sec in a coil, induced emf is 8 V. The self inductance of coil is-
(1) 0.1 H (2) 0.2 H (3) 0.4 H (4) 0.8 H
- Q.12** Two conducting coils are placed co-axially now a cell is connected in one coil then they will-
(1) attract to each other
(2) repel to each other
(3) both (1) & (2)
(4) they will not experience any force

Some important numerical problems on electromagnetic induction

Q.13 An electron beam is moving near to a conducting loop then the induced current in the loop-

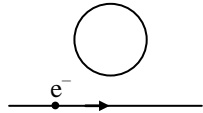

- (1) clockwise (2) anticlockwise
(3) both (4) no current

Q.14 The energy density in magnetic field B is proportional to-

- (1) $\frac{1}{B}$ (2) $\frac{1}{B^2}$ (3) B (4) B^2

Q.15 Dynamo which produces electricity, is a source of-

- (1) gravity (2) magnetism
(3) e.m.f. (4) electrolysis

Q.16 Air cored choke coil and electric bulb are connected in series with A.C. mains. A soft iron rod is inserted in coil then the intensity of electric bulb will-

- (1) decrease (2) increase
(3) fluctuate (4) remain unchanged

Q.17 When two co-axial coils having same current in same direction are bring close to each other then the value of current in both coils-

- (1) increase
(2) decrease
(3) first increase and then decrease
(4) remain same

Q.18 Lenz law represents-

- (1) relation between I and B
(2) relation between magnetic force and magnetic field
(3) relation between e.m.f. and rate of change of flux
(4) none of these

Q.19 Which type of losses does not occur in transformer-

- (1) mechanical losses (2) copper losses
(3) hysteresis losses (4) eddy current losses

Q.20 For given arrangement (in horizontal plane) the possible direction of magnetic field-

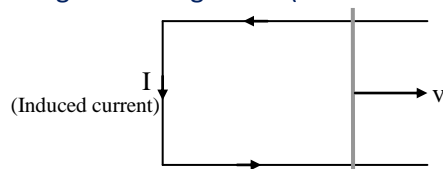

- (1) towards right
(2) towards left
(3) vertically upward
(4) vertically downward

Some important numerical problems on electromagnetic induction

- Q.21** Inductance of a solenoid is 3H and it consist of 500 turns. If number of turn make twice, then the value of self inductance becomes-
- (1) 1.5 H (2) 3 H
(3) 9 H (4) 12 H
- Q.22** A metallic disc of radius 'R' is rotating about its geometrical axis with constant angular speed ' ω ' in external magnetic field B which is perpendicular to the plane of the disc then induced emf between the centre and any peripheral point of the disc is given by-
- (1) $\pi\omega BR^2$ (2) ωBR^2
(3) $\pi\omega B \frac{R^2}{2}$ (4) $\omega B \frac{R^2}{2}$
- Q.23** Primary winding and secondary winding of a transformer has 100 and 300 turns respectively. If its input power is 60 W then output power of the transformer will be-
- (1) 240 W (2) 180 W
(3) 60 W (4) 20 W
- Q.24** A coil of 10^{-2} H inductance carries a current $I = 2\sin(100t)$ A. When current is half of its maximum value, then at that instant the induced emf in the coil will be-
- (1) 1 V (2) $\sqrt{2}$ V (3) $\sqrt{3}$ V (4) 2 V
- Q.25** Mutual inductance of two coils depends on their self inductance L_1 and L_2 as-
- (1) $M_{12} = L_1/L_2$ (2) $M_{12} = L_2/L_1$
(3) $M_{12} = \sqrt{L_1 L_2}$ (4) $M_{12} = \sqrt{L_1/L_2}$
- Q.26** In transformer, power of secondary coil is-
- (1) less than primary coil
(2) more than primary coil
(3) more in step up and less in step down than primary coil
(4) more in step down and less in step up than primary coil
- Q.27** Which of the following is correct for periodic electromagnetic induction-
- (1) maximum flux, zero emf
(2) zero flux, maximum emf
(3) zero flux, zero emf
(4) (1) & (2) both
- Q.28** If number of turns of 70 cm² coil is 200 and it is placed in a magnetic field of 0.8 Wb/m² which is perpendicular to the plane of coil and it is rotated through an angle 180° in 0.1 sec, then induced emf in coil-
- (1) 11.2 V (2) 1.12 V
(3) 22.4 V (4) 2.24 V
- Q.29** When current in a coil is reduced from 2A to 1A in 1 ms, the induced emf is 5V. The inductance of coil is-
- (1) 5 H (2) 5000 H
(3) 5 mH (4) 50 H
- Q.30** If the input voltage of a transformer is 2500 volts and output current is 80 ampere. The ratio of number of turns in the primary coil to that in secondary coil is 20 : 1. If efficiency of transformer is 100%, then the voltage in secondary coil is-

Some important numerical problems on electromagnetic induction

- (1) $\frac{2500}{20}$ volt (2) 2500×20 volt
(3) $\frac{2500}{80 \times 20}$ volt (4) $\frac{2500 \times 20}{80}$ volt

Q.31 Power dissipated in pure inductance will be-

- (1) $\frac{LI^2}{2}$ (2) $2LI^2$
(3) $\frac{LI^2}{4}$ (4) zero

Q.32 Dynamo is based on the principle of -

- (1) electro magnetic induction
(2) induced current
(3) induced magnetism
(4) faraday effect

Q.33 D.C. motor run by 120 V. If armature current at $e_b = 115$ V is 10 A, then find out current just after motor is started-

- (1) 240 A (2) 230 A (3) 120 A (4) 400 A

Q.34 Phase difference between induced emf and flux for a coil rotating in magnetic field-

- (1) 0 (2) $\pi/2$ (3) π (4) 2π

Q.35 Core of transformer is laminated-

- (1) to increase the potential ratio in primary and secondary coil
(2) to reduce eddy currents
(3) to reduce the weight of transformer
(4) none of these

Q.36 As shown in figure, a copper coil A and a wire are placed on the surface of the paper. A current of 1A flows in the wire in the directions as shown in the figure. If the magnitude of the current is raised to 2A. The direction of the induced current in the coil-

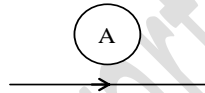

- (1) anti clock wise
(2) clock wise
(3) no current will induced
(4) none of above

Q.37 In electromagnetic induction the induced e.m.f. in a coil is independent from-

- (1) change in the flux
(2) time
(3) resistance of the circuit
(4) none of the above

Q.38 A magnet is taken towards a coil-

- (a) rapidly (b) slowly
then the induced emf is-
(1) More in (a)
(2) Less in (a)
(3) Same in both (a) and (b)
(4) More or less depends on radius

Some important numerical problems on electromagnetic induction

- Q.39** The north pole of a magnet is brought near a metallic ring as shown in the figure. The direction of induced current in the ring will be-

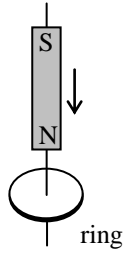

- (1) Anticlockwise
 - (2) Clockwise
 - (3) First anticlockwise and then clockwise
 - (4) First clockwise and then anticlockwise
- Q.40** The direction of induced current is such that it opposes the every cause that has produced it. This law is-
- (1) Lenz
 - (2) Farady
 - (3) Kirchoff
 - (4) Fleming
- Q.41** A conducting square loop of side ℓ and resistance R moves in its plane with a uniform velocity perpendicular to one of its sides. A uniform and constant magnetic field B exists along the perpendicular to the plane of the loop as shown in the figure. The current induced in the loop is-

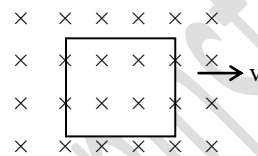

- (1) $B\ell v/R$, clockwise
 - (2) $B\ell v/R$, anticlockwise
 - (3) $2 B\ell v/R$, anticlockwise
 - (4) zero
- Q.42** A cylindrical bar magnet is kept along the axis of a circular coil. If the magnet is rotated about its axis then-
- (1) A current will be induced in coil
 - (2) No current will be induced in coil
 - (3) Only an e.m.f. will be induced in the coil
 - (4) An e.m.f. and a current both will be induced in the coil
- Q.43** A square coil of 0.01 m^2 area is placed perpendicular to the uniform magnetic field of 10^3 weber/metre². The magnetic flux linked with the coil is-
- (1) 10 weber
 - (2) 10^{-5} weber
 - (3) zero
 - (4) 100 weber
- Q.44** Consider a metal ring kept on a horizontal plane. A bar magnet is held above the ring with its length along the axis of the ring. If the magnet is dropped freely the acceleration of the falling magnet is (g is acceleration due to gravity)-

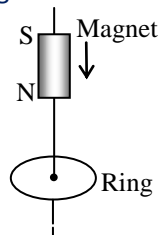

- (1) More than g
- (2) Equal to g

Some important numerical problems on electromagnetic induction

- (3) Less than g
- (4) Depend on mass of magnet

Q.45 If a copper ring is moved quickly towards south pole of a powerful stationary bar magnet, then-

- (1) current flows through the copper ring
- (2) voltage in the magnet increases
- (3) current flows in the magnet
- (4) copper ring will get magnetised

Q.46 An aluminium ring B faces an electromagnet A. The current I through A can be altered. Then which of the following statement is correct-

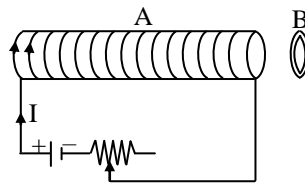

- (1) If I decreases A will repel B
 - (2) Whether I increases or decreases, B will not experience any force
 - (3) If I increases, A will repel B
 - (4) If I increases, A will attract B
- Q.47** A charge particle moves along the line AB, which lies in the same plane of a circular loop of conducting wire as shown in the figure. Then-

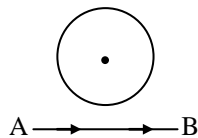

- (1) No current will be induced in the loop
 - (2) The current induced in the loop will change its direction as the charged particle passes by
 - (3) The current induced will be anticlockwise
 - (4) The current induced, will be clockwise
- Q.48** A magnet is suspended from a spring and when it oscillates, the magnet moves in and out of the coil C. The coil is connected to a galvanometer G. Then, as the magnet oscillates-

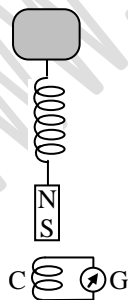

- (1) G shows no deflection
 - (2) G shows deflection to the left and right but the amplitude steadily decreases
 - (3) G shows deflection to the left and right with constant amplitude
 - (4) G shows deflection on one side
- Q.49** The induced currents always produce expanding magnetic fields round their conductors in a direction that opposes the original magnetic field. This law is called-
- (1) Lenz's law
 - (2) Kirchoff's law

Some important numerical problems on electromagnetic induction

- (3) Ohm's law (4) Fleming's rule

Q.50 As shown in the figure, a magnet is brought towards a fixed coil. Due to this the induced emf, current and the charge are E, I and Q respectively. If the speed of the magnet is double then the following statement is wrong-

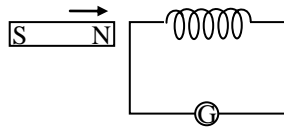

- (1) E increases
(2) I increases
(3) Q does not change
(4) Q increases
- Q.51** A coil having 500 square turns each of side 10cm is placed normal to a magnetic field which increased at a rate of 1.0 T/sec. The induced e.m.f. is-
(1) 0.1 V (2) 0.5 V (3) 1.0 V (4) 5.0 V
- Q.52** A coil of 100 turns having an average area of 100 cm² for each turn is held in a uniform field of 50 gauss. The direction of field being at right angles to the plane of coil. The field is removed in $\frac{1}{100}$ sec then average induced emf in the coil is-
(1) 0.5 V (2) 10 V (3) 15 V (4) 50 V
- Q.53** A coil of area 100 cm² has 500 turns magnetic field of 0.1 weber/meter² is perpendicular to the coil. The field is reduced to zero in 0.1 second. The induced e.m.f. in the coil is-
(1) 1 V (2) 5 V
(3) 50 V (4) zero
- Q.54** The magnetic field in a coil of 100 turns and 40 cm² an area is increased from 1 tesla to 6 tesla in 2 second. The magnetic field is perpendicular to the coil. The e.m.f. induced in it is-
(1) 10⁴ V (2) 1.2 V (3) 1.0 V (4) 10⁻² V
- Q.55** A small piece of metal wire is dragged across the gap between the pole pieces of a magnet in 0.4 sec. If magnetic flux between the pole pieces is known to be 8 × 10⁻⁴ Weber, then induced emf in the wire will be-
(1) 1 × 10⁻³ V (2) 2 × 10⁻³ V
(3) 8 × 10⁻³ V (4) 6 × 10⁻³ V
- Q.56** The current in a coil of 0.4 mH coil increases by 250 mA in 0.1 second. The induced emf will be-
(1) +1 V (2) -1 V (3) +1mV (4) -1mV
- Q.57** An inductance L and a resistance R are joined to a battery. After some time, battery is disconnected but L and R remains connected to the closed circuit. The current strength will be reduced to 37% of its original value in-
(1) RL sec (2) R/L sec
(3) L/R sec (4) 1/LR sec
- Q.58** An e.m.f. of 12 V is induced in a given coil when the current in it changes at the rate of 48 amp./min. The inductance of the coil is-
(1) 0.5 henry (2) 15 henry
(3) 1.5 henry (4) 9.6 henry

Some important numerical problems on electromagnetic induction

- Q.59** The equivalent inductance of two inductances is 2.4 henry when connected in parallel and 10 henry when connected in series. The difference between the two inductances is-
- (1) 2 henry (2) 3 henry
(3) 4 henry (4) 5 henry
- Q.60** Energy is stored in the choke coil in the form of-
- (1) Heat
(2) Electric field
(3) Magnetic field
(4) Electro-magnetic field
- Q.61** On passing 2amp. current in a coil of 50 mH. The energy stored in it is-
- (1) 1 J (2) 0.1 J (3) 0.05 J (4) 0.5 J
- Q.62** A coil of wire of a certain radius has 600 turns and a self inductance of 180 mH. The self inductance of a second similar coil of 500 turns will be-
- (1) 125 mH (2) 15 mH
(3) 75 mH (4) 100 mH
- Q.63** Self inductance of solenoid is-
- (1) Directly proportional to current flowing through the coil
(2) Directly proportional to its length
(3) Directly proportional to area of cross-section
(4) Inversely proportional to area of cross-section
- Q.64** The unit of inductance is-
- (1) Volt/ampere (2) Joule/ampere
(3) Volt-sec/ampere (4) Volt-ampere/sec
- Q.65** An e.m.f. of 15 volt is applied in a circuit containing 5 henry inductance and 10 ohm resistance. The ratio of the currents at time $t \rightarrow \infty$ and at $t = 1$ second is-
- (1) $\frac{e^{1/2}}{e^{1/2} - 1}$ (2) $\frac{e^2}{e^2 - 1}$
(3) $1 - e^{-1}$ (4) e^{-1}
- Q.66** A coil of self inductance 50 henry is joined to the terminals of a battery of emf 2 volts through a resistance of 10 ohm and a steady current is flowing through the circuit. If the battery is now disconnected the time in which the current will decay to $1/e$ of its steady value is-
- (1) 500 sec (2) 50 sec
(3) 5 sec (4) 0.5 sec
- Q.67** In the given circuit the current rises after the key is closed. At instant, when the current is 15mA. Then potential difference across the inductor is-

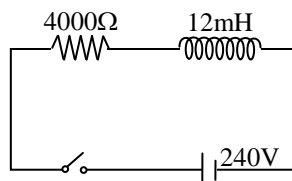

- (1) 180 V (2) 240 V
(3) 280 V (4) 90 V
- Q.68** A solenoid is at potential difference of 60 volt. If the current flowing through it is 15 amp. Then the resistance of the coil is-

Some important numerical problems on electromagnetic induction

(1) 0.25Ω (2) 0.5Ω (3) 2Ω (4) 4Ω

- Q.69** A coil of resistance 10Ω and an inductance $5H$ is connected to a 100 volt battery. Then energy stored in the coil is-
- (1) 125 erg (2) 125 J
(3) 250 erg (4) 250 J
- Q.70** A choke coil consists of 150 turns wound on a high permeability core. If the relative permeability is 3540 , permeability of free space is $4\pi \times 10^{-7}$ H/m, coil length is 5 cm and cross section area is 5×10^{-4} m², then the value of the inductance of coil is-
- (1) 8 H (2) 3 H (3) 1 H (4) 20 H
- Q.71** A coil of inductance 300 mH and resistance 2Ω is connected to a source of voltage $2V$. The current reaches half of its steady state value in-
- (1) 0.3 s (2) 0.15 s (3) 0.1 s (4) 0.05 s
- Q.72** On reducing 2 ampere current in the primary to zero in 0.01 second, an emf of 1000 volts is induced in the secondary coil. The mutual inductance of the two coils is-
- (1) 1.25 H (2) 2.5 H
(3) 5 H (4) 10 H
- Q.73** The mutual inductance of the two coils is 1.25 henry. In the first coil, the current changes at 80 amp/sec, the value of induced emf in volts in the secondary coil will be-
- (1) 12.5 (2) 64
(3) 0.016 (4) 100
- Q.74** The working of dynamo is based on principle of-
- (1) Electromagnetic induction
(2) Conversion of mechanical energy into electricity
(3) Magnetic effects of current
(4) Heating effects of current
- Q.75** A circular coil of mean radius of 7 cm and having 4000 turns is rotated about its axis and of the diameter at the rate of 1800 revolutions per minute in the earth's magnetic field 0.5 gauss, the induced emf in coil will be-
- (1) 1.158 V (2) 0.58 V
(3) 0.29 V (4) 5.8 V
- Q.76** A metallic conductor of $1m$ length is rotated vertically about its one end at an angular velocity of 5 rad/sec, if the horizontal component of earth's field is 0.2×10^{-4} T, the voltage generated at both ends of the conductor will be-
- (1) 5 mV (2) 5×10^{-4} V
(3) 50 mV (4) $50 \mu V$
- Q.77** A long horizontal metallic rod with length along the east-west direction is falling under gravity. The potential difference between its two ends will-
- (1) Be zero (2) Be constant
(3) Increase with time (4) Decrease with time
- Q.78** A horizontal wire with length along the east-west direction is falling then-
- (1) No induced emf
(2) No induced current
(3) An induced current which will flow from west to east

Some important numerical problems on electromagnetic induction

(4) An induced current which will flow from east to west

- Q.79** A two metre wire is moving with a velocity of 1m/sec perpendicular to a magnetic field of 0.5 Wb/m^2 . The induced emf will be-
- (1) 0.5 V (2) 0.1 V
(3) 1 V (4) 2 V

- Q.80** Consider the situation shown in the figure. The wire AB is slide over two parallel rails with a constant velocity. If the wire AB is replaced by a semi-circular wire, the magnitude of the induced current will-

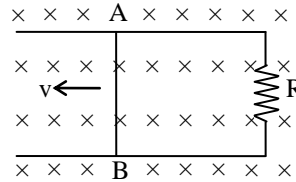

- (1) Increase
(2) Remain the same
(3) Decrease
(4) Increase or decrease depending on whether the semicircle bulges towards the resistance or away from it
- Q.81** An aeroplane in which the distance between the tips of the wings is 50 meters is flying horizontally with a speed of 360 km/hour over a place where the vertical component of earth's magnetic field is $2.0 \times 10^{-4} \text{ T}$. The potential difference between the tips of the wings would be-
- (1) 0.1 V (2) 1.0 V
(3) 0.2 V (4) 0.01 V
- Q.82** A conducting rod of length L is falling with a velocity v perpendicular to a uniform horizontal magnetic field B . The potential difference between its two ends will be-
- (1) $2 BLv$ (2) BLv
(3) $\frac{1}{2} BLv$ (4) $B^2 L^2 v^2$
- Q.83** If the vertical component of earth's magnetic field be $6 \times 10^{-5} \text{ Wb/m}^2$, then what will be the induced potential difference between the rails of a meter gauge when a train is running on them with a speed of 36 km/hr –

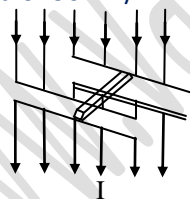

- (1) $2 \times 10^{-4} \text{ V}$ (2) $6 \times 10^{-4} \text{ V}$
(3) $3 \times 10^{-4} \text{ V}$ (4) $9 \times 10^{-4} \text{ V}$
- Q.84** For an electric motor, the voltage equation is-
- (1) $E = e_b - I_a R_a$ (2) $E = e_b + I_a R_a$
(3) $E = e_b / I_a R_a$ (4) $E = I_a R_a / e_b$
- Q.85** In a D.C. motor, the current in the armature is maximum when the-
- (1) Motor has just started motion
(2) Motor has attained maximum speed
(3) Motor is switched off
(4) Motor moves at an average speed
- Q.86** In a D.C. motor the back emf will be maximum at the-
- (1) Start condition
(2) Off condition

Some important numerical problems on electromagnetic induction

- (3) Position of maximum speed
(4) All the time
- Q.87** In a motor when 4A current flows through it the power consumed is 20 W and the induced potential difference is 220 V. The applied emf is-
(1) 220 V (2) 225 V
(3) 240 V (4) 260 V
- Q.88** If the rotational velocity of a motor armature is doubled, then back emf will-
(1) Become half (2) Become double
(3) Become quadruple (4) Remain unchanged
- Q.89** As the speed of the fan increase, current-
(1) Increases
(2) Decreases
(3) Remains the same
(4) Becomes maximum when speed is maximum
- Q.90** The armature of D.C. motor has 20Ω resistance it draws current of 1.5 ampere when run by 220 volts D.C. supply. The value of back e.m.f. induced in it will be-
(1) 150 V (2) 170 V
(3) 180 V (4) 190 V
- Q.91** Work of electric motor is-
(1) To convert AC into DC
(2) To convert DC into AC
(3) Both (1) and (2)
(4) To convert AC into mechanical work
- Q.92** The turn ratio in a step down transformer is 3:1. If the primary coil is joined to a battery of emf 1.5 volts, the value of voltage in the secondary coil is-
(1) 1.5 volts (2) zero
(3) 4.5 volts (4) 0.5 volts
- Q.93** The efficiency of a transformer is maximum, because-
(1) No part of the transformer is in motion
(2) It creates maximum voltage
(3) It creates minimum voltage
(4) None of the above
- Q.94** In a step up transformer the ratio of turns of the primary and the secondary is 1:25. If the input voltage is 230 V and the current through the load is 2A, then the current in the primary is-
(1) 50 A (2) 25 A
(3) 12.5 A (4) 6.25 A
- Q.95** The primary of a transformer has 40 turns when an input voltage of 20V is applied, the output voltage is 25 volt. The number of turns in the secondary is-
(1) 250 (2) 100
(3) 10 (4) 50
- Q.96** In order to avoid eddy currents in the core of a transformer-
(1) the number of turns in the secondary coil is made considerably large
(2) A laminated core is used
(3) A step down transformer is used
(4) A high voltage alternating weak current is used

Some important numerical problems on electromagnetic induction

- Q.97** In a transformer the primary has 500 turns and secondary has 50 turns. 100 volts are applied to the primary coil, the voltage developed for the secondary will be-
- (1) 1 V
 - (2) 10 V
 - (3) 1000 V
 - (4) 10,000 V
- Q.98** The number of turns in the primary and secondary of transformer are N_p and N_s respectively. The resistance of the secondary circuit is R_s . Then equivalent resistance of primary circuit-
- (1) $R_s \frac{N_s}{N_p}$
 - (2) $R_s \left(\frac{N_s}{N_p} \right)^2$
 - (3) $R_s \frac{N_p}{N_s}$
 - (4) $R_s \left(\frac{N_p}{N_s} \right)^2$
- Q.99** Quantity that remains unchanged in a transformer is-
- (1) Voltage
 - (2) Current
 - (3) Frequency
 - (4) None of above
- Q.100** Which quantity is increased in step down transformer-
- (1) Current
 - (2) Voltage
 - (3) Power
 - (4) Frequency
- Q.101** The core of a transformer is laminated so that-
- (1) The ratio of the voltage in the secondary to that in the primary may be increased
 - (2) Energy losses due to eddy currents may be minimised
 - (3) The weight of the transformer may be reduced
 - (4) Rusting of the core may be prevented
- Q.102** The number of turns in the primary and secondary of a transformer are 1000 and 3000 respectively. If 80 volt A.C. is applied to the primary coil of the transformer, then the potential difference per turn of the secondary coil would be-
- (1) 240 volt
 - (2) 2400 volt
 - (3) 24 volt
 - (4) 0.08 volt
- Q.103** A primary of a step down transformer used for ringing door bell has 2000 turns of fine wire and the secondary has 100 turns. This transformer when connected to a 110 V A.C. source will deliver at its secondary a potential difference of-
- (1) 2200 V
 - (2) 55 V
 - (3) 11 V
 - (4) 5.5 V
- Q.104** The electric power is transferred to a far distance at high potential because-
- (1) It stops the wire theft
 - (2) To minimize power loss
 - (3) Generator gives only high potential
 - (4) Electric power is transferred early due to high potential
- Q.105** A transformer is employed to-
- (1) Obtain a suitable D.C. voltage
 - (2) Convert D.C. into A.C.
 - (3) Obtain a suitable A.C. voltage
 - (4) Convert A.C. into D.C.

Some important numerical problems on electromagnetic induction

- Q.106** In a transformer 220 V A.C. voltage is increased to 2200 volts. If the number of turns in the secondary are 2000, then the number of turns in the primary will be-
- (1) 200 (2) 100
(3) 50 (4) 20
- Q.107** The primary winding of a transformer has 100 turns and its secondary winding 200 turns. The primary is connected to an A.C. supply of 120 V and the current flowing in it is 10 A.C. the voltage and the current in the secondary are-
- (1) 240 V, 5A (2) 240V, 10A
(3) 60 V, 20 A (4) 120 V, 20 A
- Q.108** An ideal transformer has 100 turns in the primary and 250 turns in the secondary. The peak value of the A.C. is 28V the r.m.s. secondary voltage is nearest to-
- (1) 50V (2) 70V
(3) 100V (4) 40V
- Q.109** A transformer is employed to reduce 220V to 11V. The primary draws a current of 5A and the secondary 90A. The efficiency of the transformer is-
- (1) 20% (2) 40%
(3) 70% (4) 90%
- Q.110** The alternating voltage induced in the secondary coil of a transformer is mainly due to-
- (1) A varying electric field
(2) A varying magnetic field
(3) The vibrations of the primary coil
(4) The iron core of the transformer
- Q.111** A transformer connected to 220 volt line shows an output of 2A at 11000 volt. The efficiency is 100%. The current drawn from the line is-
- (1) 100 A (2) 200 A (3) 22 A (4) 11 A
- Q.112** The ratio of the secondary to the primary turns in a transformer is 3 : 2 and the output power is P. Neglecting all power losses, the input power must be-
- (1) $\frac{P}{2}$ (2) P (3) $\frac{2P}{3}$ (4) $\frac{3P}{2}$
- Q.113** If primary winding of a transformer were connected to a battery, the current in it will-
- (1) Increase
(2) Remain constant
(3) Decrease
(4) First (1) and then (3)
- Q.114** A step up transformer has turn ratio 10 : 1. A cell of e.m.f. 2 volts is fed to the primary. Secondary voltage developed is-
- (1) 20 V (2) 10 V (3) 2 V (4) Zero
- Q.115** A magnet is dropped down an infinitely long vertical copper tube. Then-
- (1) The magnet moves with continuously decreasing velocity and ultimately comes to rest
(2) The magnet moves with continuously increasing velocity and ultimately acquires a constant terminal velocity
(3) The magnet moves with continuously increasing velocity and acceleration
(4) The magnet moves with continuously increasing velocity but constant acceleration

Some important numerical problems on electromagnetic induction

Q.116 A circular loop of radius r is placed in a region where magnetic field increases with respect to time as $B(t) = at$ then induced emf in coil-

- (1) $\pi r^2 a$ (2) $3\pi r^2 a$ (3) $2\pi r^2 a$ (4) None

Q.117 A circular loop of radius r is moved away from a current carrying wire then induced current in circular loop will be-

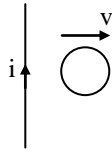

- (1) clockwise (2) anti clockwise
(3) not induced (4) none of them

Q.118 The electric generator produce electric current based on which principle-

- (1) Ohm's law (2) Faraday's law of EMI
(3) Ampere's law (4) Biot-savart's law

Q.119 A rectangular loop of sides a and b is placed in magnetic field B . The emf induced in coil when normal of coil makes angle ωt with B –

- (1) $BA\omega \cos\omega t$ (2) $BA\omega \sin\omega t$
(3) $-BA\omega \sin\omega t$ (4) $-BA\omega \cos\omega t$

Q.120 One conducting U tube can slide inside another as shown in figure, maintaining electrical contacts between the tubes. The magnetic field B is perpendicular to the plane of the figure. If each tube moves towards the other at a constant speed v , then the induced emf in the circuit, where ℓ is the width of each tube-

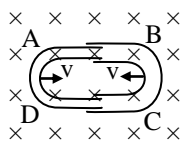

- (1) $2B\ell v$ (2) Zero (3) $-B\ell v$ (4) $B\ell v$

Q.121 A coil of inductance 300 mH and resistance 2Ω is connected to a source of voltage 2V . The current reaches half of its steady state value in-

- (1) 0.3 s (2) 0.15 s (3) 0.1 s (4) 0.05 s

Q.122 Which of the following units denotes the dimensions ML^2/Q^2 , where Q denotes the electric charge-

- (1) Weber (2) Wb/m^2 (3) Henry (4) H/m^2

Q.123 In an AC generator, a coil with N turns, all of the same area A and total resistance R , rotates with frequency ω in a magnetic field B . The maximum value of emf generated in the coil is-

- (1) $NAB\omega$ (2) $NABR\omega$
(3) NAB (4) $NABR$

Q.124 The flux linked with a coil at any instant ' t ' is given by $\phi = 10t^2 - 50t + 250$. The induced emf at $t = 3 \text{ s}$ is-

- (1) 190 V (2) -190 V
(3) -10 V (4) 10 V

Q.125 An inductor ($L = 100 \text{ mH}$), a resistor ($R = 100\Omega$) and a battery ($E = 100\text{V}$) are initially connected in series as shown in the figure. After a long time the battery is disconnected after short circuiting the points A and B . The current in the circuit 1 ms after the short circuit is-

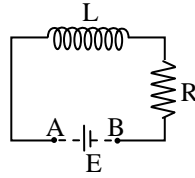

- (1) 1A (2) $1/e$ A (3) e A (4) 0.1 A

- Q.126** An ideal coil of 10H is connected in series with a resistance of 5Ω and a battery of 5V. 2 seconds after the connection is made, the current flowing in amperes in the circuit is-
- (1) e (2) $e - 1$
(3) $(1 - e^{-1})$ (4) $(1 - e)$
- Q.127** Two coaxial solenoids are made by winding thin Cu wire over a pipe of cross-sectional area $A = 10 \text{ cm}^2$ and length = 20 cm. If one of the solenoids has 300 turns and the other 400 turns, their mutual inductance is-
- (1) $2.4 \pi \times 10^{-5} \text{ H}$ (2) $4.8 \pi \times 10^{-4} \text{ H}$
(3) $4.8 \pi \times 10^{-5} \text{ H}$ (4) $2.4 \pi \times 10^{-4} \text{ H}$

IMPORTANT PRACTICE QUESTION SERIES FOR IIT-JEE EXAM - 5

These questions of two statements each, printed as Assertion and Reason. While answering these Questions you are required to choose any one of the following four responses.

- (A) If both Assertion & Reason are true & the Reason is a correct explanation of the Assertion.
(B) If both Assertion and Reason are true but Reason is not a correct explanation of the Assertion.
(C) If Assertion is true but the Reason is false.
(D) If Assertion & Reason both are false.

- Q.1** **Assertion** : A thin aluminium disc, spinning freely about a central pivot, is quickly brought to rest when placed between the poles of a strong U-shaped magnet.
Reason : A current induced in a disc rotating in a magnetic field produces a force which tends to oppose the motion of the disc.
(1) A (2) B (3) C (4) D
- Q.2** **Assertion** : A step up transformer can also as a step down transformer.
Reason : This is because $\frac{E_s}{E_p} = \frac{n_s}{n_p}$
(1) A (2) B (3) C (4) D
- Q.3** **Assertion** : When we consider mutual induction of two coils, their self induction is taken as zero.
Reason : Self induction and mutual induction are effective simultaneously.
(1) A (2) B (3) C (4) D
- Q.4** **Assertion** : In a given situation, the direction of induced current given by Lenz's Law and Fleming's right hand rule is the same.
Reason : Statement of both the laws is the same.
(1) A (2) B (3) C (4) D
- Q.5** **Assertion** : An inductor can not have zero resistance.
Reason : This is because inductor has to be made up of some material, which must have some resistance.
(1) A (2) B (3) C (4) D
- Q.6** **Assertion** : Whenever magnetic flux linked with the coil changes with respect to time, then an emf is induced in it.

Some important numerical problems on electromagnetic induction

Reason : According to lenz law, the direction of induced current in any coil in such a way that it always opposes the cause by which it is produced.

- (1) A (2) B (3) C (4) D

Q.7 Assertion : Magnetic flux through the wood ring changes with respect to time then an emf is induced in it.

Reason : Two basic difference between an electric line and a magnetic line of force is that former is discontinuous and latter is continuous or endless.

- (1) A (2) B (3) C (4) D

Q.8 Assertion : When a bar magnet moves along the axis of conducting coil, then its kinetic energy and a part of magnetic energy of bar magnet is converted into electrical energy of coil.

Reason : Lenz law is based on conservation of energy.

- (1) A (2) B (3) C (4) D

Q.9 Assertion : If magnetic flux through any circuit is changes then an emf in induced in it. This emf is equal to negative of rate of change of flux.

Reason : Direction of induced emf is always such that it always opposes the cause by which it is produced.

- (1) A (2) B (3) C (4) D

Q.10 Assertion : The mutual inductance M between two coils of self inductances L_1 and L_2 is given by $M \leq \sqrt{L_1 L_2}$.

Reason : The energy density (i.e. energy per unit volume) at an point, where the magnetic field B is given by $\frac{B^2}{2\mu_0}$.

- (1) A (2) B (3) C (4) D

Q.11 Assertion : Voltage across L (see figure) at $t = 0$ is E .

Reason : Because $E = V_L + V_R$ and at $t = 0, i = 0$

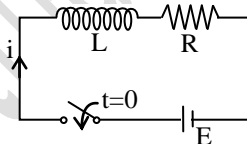

- (1) A (2) B (3) C (4) D

Q.12 Assertion : At any instant, if the current through an inductor is zero, then the induced emf may not be zero.

Reason : An inductor tends to keep the flux (i.e. current) constant.

- (1) A (2) B (3) C (4) D

Q.13 Assertion : Due to high inductance of any coil, the current attains it peak value relatively late in it.

Reason : Due to self induction, coil opposes the flow of current through it.

- (1) A (2) B (3) C (4) D

Q.14 Assertion : A current is flowing through a coil with 5 volt battery. If self inductance of coil is increased then circuit takes more time to acquires its current peak.

Reason : Inductance strongly opposes the flow of current through it.

- (1) A (2) B (3) C (4) D

Q.15 Assertion : Unlike charges are projected in opposite direction in transverse magnetic field, then they are deflected in same directions.

Reason : If a voltmeter connected across two peripheral points of faraday copper disc generator, its reading is zero.

Some important numerical problems on electromagnetic induction

(1) A (2) B (3) C (4) D

Q.16 Assertion : Faraday's copper disc generator is based on dynamic electromagnetic induction.

Reason : Alternating current generator is based on periodic electromagnetic induction.

(1) A (2) B (3) C (4) D

Q.17 Assertion : When a conducting rod moves in uniform transverse magnetic field with uniform speed which is perpendicular to its length, then potential difference may developed across its ends.

Reason : In any conductor, free electrons and free positive ions are available.

(1) A (2) B (3) C (4) D

Q.18 Assertion : If a steel core is used in a transformer in place of soft iron core then hysteresis losses are increased.

Reason : Steel core is easily magnetised but it is easily not demagnetised by the alternating magnetic field.

(1) A (2) B (3) C (4) D

Q.19 Assertion : Electromagnets are made of soft iron.

Reason : Soft iron has low retentivity and low coercive force.

(1) A (2) B (3) C (4) D

Q.20 Assertion : A thin aluminium disc, spinning freely about a central pivot, is quickly brought to rest when placed between the poles of a strong U-shaped magnet.

Reason : A current induced in a disc rotating in a magnetic field produces a torque which tends to oppose the disc's motion.

(1) A (2) B (3) C (4) D

Q.21 Assertion : We use a thick wire in the secondary of a step down transformer to reduce the produced heat.

Reason : When the plane of the armature coil is parallel to the line of force of magnetic field, the magnitude of induced e.m.f. is maximum.

(1) A (2) B (3) C (4) D

Q.22 Assertion : The quantity L/R possesses dimension of time.

Reason : To reduce the rate of growth of current through a solenoid, we should increase the time constant (L/R).

(1) A (2) B (3) C (4) D

Q.23 Assertion : An electric field is induced in a closed loop where magnetic flux is varied. The induced \vec{E} is not a conservative field.

Reason : The line integral $\vec{E} \cdot d\vec{\ell}$ around the closed loop is non zero.

(1) A (2) B (3) C (4) D

IMPORTANT PRACTICE QUESTION SERIES FOR IIT-JEE EXAM - 1 (ANSWERS)

Q.No.	1	2	3	4	5	6	7	8	9	10	11	12	13	14	15	16	17	18	19	20
Ans.	2	4	1	1	4	3	3	4	4	4	1	4	4	3	4	1	2	3	2	1
Q.No.	21	22	23	24	25	26	27	28	29	30	31	32	33	34	35	36	37	38	39	40
Ans.	4	1	1	3	1	2	2	2	2	4	3	2	2	2	3	4	1	1	3	4
Q.No.	41	42	43	44	45	46	47	48	49	50	51	52	53	54	55	56	57	58	59	60
Ans.	1	3	4	1	1	1	4	3	4	2	2	2	3	3	3	4	1	4	3	
Q.No.	61	62	63	64	65	66	67	68	69	70	71	72	73	74	75	76	77	78		
Ans.	3	2	1	3	2	2	2	1	2	1	3	1	1	2	3	1	2	2		

IMPORTANT PRACTICE QUESTION SERIES FOR IIT-JEE EXAM - 2 (ANSWERS)

Q.No.	1	2	3	4	5	6	7	8	9	10	11	12	13	14	15	16	17	18	19	20
Ans.	4	3	2	3	2	1	4	1	1	2	1	1	1	1	1	1	3	2	2	2
Q.No.	21	22	23	24	25	26	27	28	29	30	31	32	33	34	35	36	37	38	39	40
Ans.	3	1	3	2	1	4	2	4	2	1	1	1	3	1	1	1	2	3	2	2
Q.No.	41	42	43	44	45	46	47	48	49	50	51	52	53	54	55	56	57	58	59	60
Ans.	2	1	2	2	1	4	4	1	1	1	3	3	2	1	1	2	2	4	4	1
Q.No.	61	62	63	64	65	66	67	68	69	70	71	72	73	74	75	76	77	78	79	80
Ans.	3	1	3	4	3	2	4	1	2	4	1	1	2	2	1	4	2	1	4	2
Q.No.	81	82	83	84	85	86	87													
Ans.	1	1	4	1	2	1	2													

IMPORTANT PRACTICE QUESTION SERIES FOR IIT-JEE EXAM - 3 (ANSWERS)

Q.No.	1	2	3	4	5	6	7	8	9	10	11	12	13	14	15	16	17	18	19	20
Ans.	3	3	4	1	4	2	3	2	1	1	4	1	3	3	4	1	1	1	2	3
Q.No.	21	22	23	24	25	26	27	28	29	30	31	32	33	34	35	36				
Ans.	3	2	2	4	1	1	1	2	1	2	1	1	2	3	1	2				

IMPORTANT PRACTICE QUESTION SERIES FOR IIT-JEE EXAM - 4 (ANSWERS)

Some important numerical problems on electromagnetic induction

Q.No.	1	2	3	4	5	6	7	8	9	10	11	12	13	14	15	16	17	18	19	20
Ans.	3	4	2	2	3	1	1	4	2	2	2	2	4	4	3	1	2	3	1	4
Q.No.	21	22	23	24	25	26	27	28	29	30	31	32	33	34	35	36	37	38	39	40
Ans.	4	4	3	3	3	1	4	3	3	1	4	1	1	2	2	2	3	1	1	1
Q.No.	41	42	43	44	45	46	47	48	49	50	51	52	53	54	55	56	57	58	59	60
Ans.	4	2	1	3	1	3	2	2	1	4	4	1	2	3	2	4	3	2	1	3
Q.No.	61	62	63	64	65	66	67	68	69	70	71	72	73	74	75	76	77	78	79	80
Ans.	2	1	3	3	2	3	1	4	4	3	3	3	4	1	2	4	3	3	3	2
Q.No.	81	82	83	84	85	86	87	88	89	90	91	92	93	94	95	96	97	98	99	100
Ans.	2	2	2	2	1	3	2	2	2	4	4	2	1	1	4	2	2	4	3	1
Q.No.	101	102	103	104	105	106	107	108	109	110	111	112	113	114	115	116	117	118	119	120
Ans.	2	4	4	2	3	1	1	1	4	2	1	2	2	4	2	1	1	2	2	1
Q.No.	121	122	123	124	125	126	127													
Ans.	3	3	1	3	2	3	4													

IMPORTANT PRACTICE QUESTION SERIES FOR IIT-JEE EXAM - 5 (ANSWERS)

Q.No.	1	2	3	4	5	6	7	8	9	10	11	12	13	14	15	16	17	18	19	20
Ans.	1	1	4	3	1	2	2	1	3	2	1	2	3	3	2	2	3	3	1	1
Q.No.	21	22	23																	
Ans.	2	1	1																	